

A METHOD FOR PROCESSING OF GREEN TEA

S. Samarasingham

(Tea Research Institute of Sri Lanka, Talawakele, Sri Lanka)

A method to process a form of green tea utilizing a Chinese de-enzyming machine 'Chekiang Green Tea Model 180' and conventional black tea processing machines is described. This method can be successfully adopted in black tea manufacturing factories in Sri Lanka to process green tea with minimum capital expenditure. Tea leaves used for this investigation were the usual estate harvested flush and was conducted for a period of six months.

INTRODUCTION

There are two main forms of tea, viz. the fermented and the non-fermented forms. Black tea belongs to the fermented form of tea. The main group of chemical substances present in the flush is polyphenols which undergo oxidative changes during the stage of fermentation in the manufacture of black tea. The oxidized polyphenols form coloured substances referred to as theaflavins and thearubigins which are mainly responsible for the colour and character of black tea liquor.

On the other hand green tea is a non-fermented form of tea. The method of processing is basically different from that of black tea as green tea is not subjected to fermentation which stage is totally eliminated by a process called de-enzyming or inactivation of the enzyme polyphenol oxidase. The processed green tea retains the green colour and the chemical composition of the green leaf without major changes.

Traditional green tea producing countries like China, Japan, Taiwan, etc. cultivate the indigenous China jat (*Camellia sinensis* var. *sinensis*) in which the flush is small in size and dark green in colour. They contain low amounts of polyphenols and high amounts of amino acids compared to the flush of the broad leaved Assam variety. Higher ratios of amino acids to polyphenols and low levels of polyphenols are desirable leaf qualities for the production of good quality green tea (Wickremasinghe, 1978). Indonesia and India produce green teas from the flush of *Camellia sinensis* var. *assamica*, which are inferior in appearance and liquor characteristics. The liquor is noticeably bitter and harsher compared to the Chinese or Japanese green teas mainly due to the very high amounts of polyphenols present in the leaves.

Studies of polyphenols and amino acids in the flush of China and Assam varieties of tea (Wickremasinghe, 1978) show significant differences.

Flush	Polyphenols (% dry weight)	Amino acids (% dry weight)
China jat	10 - 17	6
Assam jat	25 - 35	4

There are two popular systems of processing green tea, the Chinese and the Japanese systems, the former utilizes the hot pan method for de-enzyming whereas the latter uses the steam method. For the Assam variety of tea, which contains high amounts of polyphenols, the Chinese method of processing is preferred (Wickremasinghe, 1978). The hot pan method employs higher temperatures than the steam method and high temperatures are known to reduce the principal flavanols which are responsible for the bitterness.

There are different types of panning machines available; the working and capacities of these machines vary to a wide extent. The 'Chekiang Green Tea Model 180' panning machine is designed for use in a continuous system of green tea manufacture and has the largest capacity of all panning machines, with a specified rate of production of about 300 kg h⁻¹. This machine was gifted by the Government of the People's Republic of China to the Tea Research Institute of Sri Lanka under an aid scheme in 1977.

According to available information (Elliot and Whitehead, 1926; Cook, 1931; Eden, 1958) Sri Lanka produced and exported green tea to India, Canada and Russia around 1910. Sri Lanka's green tea export in 1912 was 7, 937, 308 lb. but later on gradually decreased and in 1930 the quantity exported was 1, 264, 151 lb. The method of processing used was similar to the method used in India being a combination of Japanese and Chinese methods (Anon. 1974). The de-enzyming process was by the steam method while the rest of the processing operations was by the Chinese method, but utilizing the available black tea machinery. Green tea grades exported were Young Hyson, Hyson 1 and 2, Gunpowder and Dust.

The aim of this paper is to briefly describe the work carried out on the method of green tea processing.

EXPERIMENTAL

The main trial on a commercial basis was conducted at Lamiliere factory of St. Coombs estate of the Tea Research Institute for a period of six months. In this study a method was evolved for the production of commercial type green tea employing the 'Chekiang Green Tea Model 180' panning machine as well as the available conventional black tea processing machines from the usual estate harvested mixed flush of low jat (China) seedling and a few varieties of high jat clonal tea.

De-enzyming Machine 'Chekiang Green Tea Model 180'

This machine consists of four parts (see Figs 1 and 2)

1. Green leaf conveyor
2. Rotating barrel
3. Leaf discharging and moist air exhausting device
4. Furnace

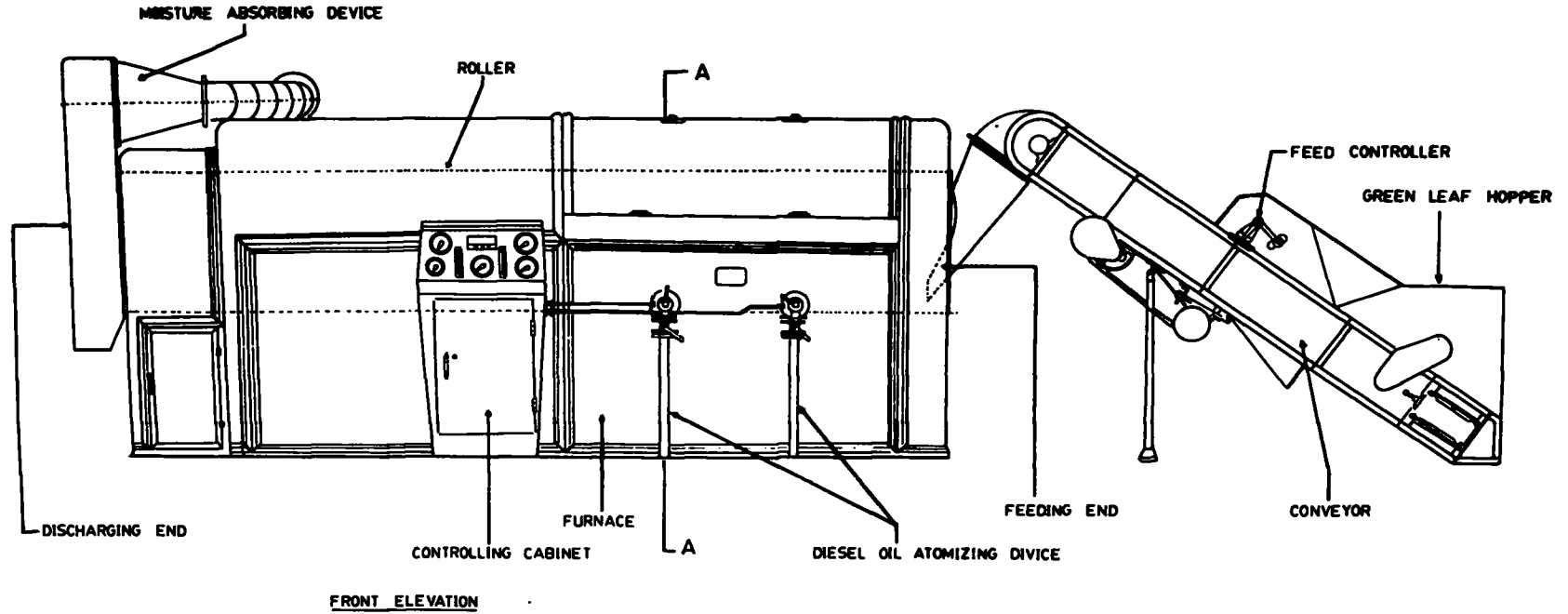

Fig. 1 — Major parts of the 'Chekiang Green Tea Model 180' roller type de-enzyming machine.

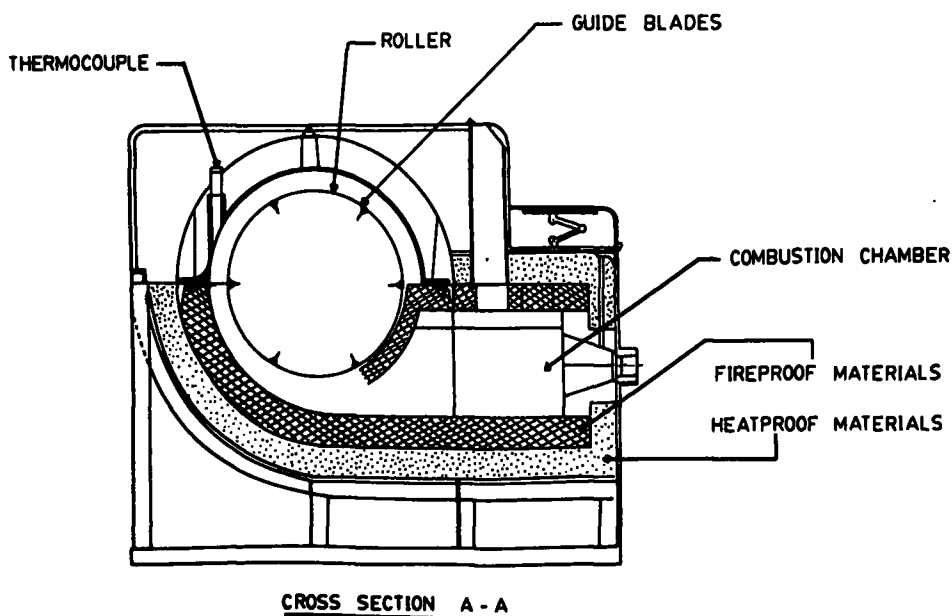

Fig. 2 — Cross section of the machine at A-A showing the position of the roller (barrel) in the furnace

The rotating barrel is constructed of 0.8 cm thick steel and inside the barrel are fitted six guide plates. These guide plates while assisting proper de-enzyming prevent portions of leaf getting over dried or burnt by their throwing action. They also help push slowly the leaf to the discharge end of the barrel. The barrel is 4.5 m long with a diameter of 0.8 m and rotates at a speed of 28 rpm. Leaf is delivered to the feed end of the barrel by a conveyor and the processed leaf is discharged at the other end. At the discharge point moist air is also sucked out of the barrel. The rotating barrel is encased by a combustion chamber where either auto diesel oil or heavy diesel oil is used as fuel. The machine is provided with two thermometers. One is to read the furnace temperature near the feed end of the barrel and the other to read the exhaust air temperature at the leaf discharge point. The average consumption rate of heavy diesel to maintain a furnace temperature of about 400 - 450°C is in the region of 27 l h⁻¹.

Processing Method

The processing method can be separated into six stages as follows:

- (a) Panning
- (b) Cooling
- (c) Rolling
- (d) Roll-breaking
- (e) Drying
- (f) Sifting and sorting

RESULTS AND DISCUSSION

(a) Panning

The process of roasting the fresh green leaf on a hot metal surface, usually cast iron, to inactivate the enzyme is referred to as panning. This operation is accomplished in the 'Chekiang Green Tea Model 180' de-enzyming machine. The available flush material varies widely in succulence and quality depending on the jat of tea, climate and cultural operations. Operating conditions of the 'Chekiang Green Tea Model 180' de-enzyming machine were determined by examining furnace temperatures ranging from 250 to 550°C, exhaust temperatures from 45 to 65°C, feed rates from 5 to 15 kg min⁻¹ as well as single and double passes. The double pass system despite the low barrel and exhaust temperatures, 250°C and 45°C respectively, did not prove satisfactory. The colour of the panned leaf turned reddish and also the leaf was very gummy. During rolling the leaf formed lumps which are difficult to roll-break. Low feed rates and high barrel temperatures over-dried or charred the leaf. High rate of feeding and exhaust temperatures below 55°C did not satisfactorily inactivate enzymes. The operating conditions which gave satisfactory results were furnace temperatures that were between 400°C and 450°C, exhaust temperatures of about 60°C and depending on the succulence of the leaf a feed rate of 5.5 to 7.5 kg min⁻¹.

Under such conditions of the de-enzyming method the appearance of the treated flush was yellowish green and the leaf was less sticky. The weight of the leaf was reduced by about 25 - 30 per cent. When the exhaust temperature was increased to above 65°C the leaf tends to over dry and leaf margins char. At exhaust temperatures below 55°C the inactivation of the fermenting enzyme was not complete. Both conditions affected the appearance and liquoring characteristics of the processed tea.

(b) Cooling

The next stage in the processing is cooling. The main objective of this operation is to stop destruction of the chlorophyll by excessive heat and to prevent the "cooking" of leaf by water vapour. If "cooking" of leaf is allowed to take place the panned tea character will be adversely affected. Further this process improves the condition of the leaf for the next operation of rolling.

Panned leaf was cooled immediately in a stream of cold air. This was done by manually spreading the panned leaf in front of a 40 cm (16") X-pel air fan mounted on a 0.6m (2 ft) stand. The appearance of this leaf at this stage was somewhat similar to a soft withered leaf in orthodox black tea manufacture. The leaf tends to be gummy.

(c) Rolling

The objective here is to twist the leaf, rupture the cells and to distribute the juice on the leaf surface and to obtain some dhools. To achieve this a light rolling was carried out on two sizes of single action orthodox rollers fitted with crescent battens and 35° standard cones. A few variations in rolling were investigated and a 3 x 20 mins light rolling was found suitable. The first rolling was carried out on a 110 cm (44") roller and the balance rollings were done on 90 cm (36") rollers with roller speeds of 40 rpm.

(d) Roll-breaking

Roll-breaking was carried out on a standard 1.3m (4.5 ft) rotary roll-breaker fitted with a No. 4 GI mesh. The roll-breaking operation was difficult because of the roll-breaker mesh. Frequent cleaning of the mesh had to be done using a scrubbing brush. The total quantity of dhools obtained from the three rolls was about 40-45 per cent.

(e) Drying (Firing)

The big bulk contained considerable proportions of lumps which had to be loosened manually as far as possible before drying. The firing was carried out in Walker's pressure driers 'Standard' model MK 1 which are tilting tray type driers. Since firing was carried out keeping the inlet air temperature at 90°C, exhaust air temperature at about 57°C and a firing period of 24 mins, the feed rate of the rolled leaf was regulated between 70-80 kg h⁻¹. The moisture content of the fired tea was about 4.0 per cent.

(f) Sifting and sorting

Sifting and sorting of the green tea, as in the case of black tea, have to be done carefully. The appearance of the various grades including the bloom is an important consideration in marketing. Though some of the sifting machines used for grading tea are somewhat different, black tea sifting machines can be used quite successfully.

Sifting of green tea was done according to the orthodox black tea method on the day following manufacture. The sifting machines used were Myddleton stalk extractor, Michie sifter, Japanese tea cutter and suction winnower. The perforations of the two bubble trays of the Myddleton stalk extractor was top tray 0.47 cm (3/16") and bottom 0.6 cm (1/4"). The Japanese tea cutter was intended to cut the large size particles to the size of BOP teas, but with the green tea it did not give a satisfactory performance.

The techniques of sifting and sorting adopted were as follows: Dhools and big bulk were treated separately. Initially the dhools were sifted on the Myddleton stalk extractor. Dhools which came through the bottom tray were resifted and the final fraction that passed through the bottom tray was taken as Pekoe. The large size particles that came over the Myddleton stalk extractor were cut and resifted. The fraction that passed through the top tray was resifted on a Michie sifter fitted with No. 10 mesh tray on top and No. 30 mesh tray (small) at the bottom. The fraction over 10 mesh tray was Pekoe. The fraction over No. 30 mesh tray formed one grade and a mixture of BOP and BOPF. The fraction through No. 30 mesh tray was Dust.

The big bulk was sifted on the Myddleton stalk extractor to remove the small leaf grades Pekoe, BOP and Fannings and Dust. The rest was sifted on the Michie sifter with a No. 8 mesh tray on top. Feeding was manually regulated to extract the good OPs and what went over No. 8 mesh tray was taken as OP No. 2. All grades except the Dust were winnowed and the winnowed light particles went into the Broken Tea grade. The grade percentages obtained were as follows:

OP	- 7.0	P	- 41.0	BT	- 6.0
OP No. 2	- 16.0	BOP & BOPF	- 26.0	Dust	- 4.0

The Chinese green tea grades have different names such as Young Hyson, Hyson, Gunpowder, Sow Mee, Twanty, etc. We did not want to assign Chinese green tea grade names to the graded teas, because we did not correctly adopt the Chinese green tea grading method. The Dust grade which has low market value was minimized as much as possible. These grade percentages can be varied by suitable changes in the rolling and grading methods.

The processed green tea amounted to about 2000 kg per month and was bought by a tea firm in Pakistan who were satisfied with the quality of the green tea produced by us.

CONCLUSIONS

The production of good quality Chinese type green teas is not possible in Sri Lanka, because the variety of tea grown here is not suitable. However, average quality green teas of commercial importance can be manufactured. These teas appear to have market potentials in Asian, African and American countries.

Our green teas tasted more bitter and astringent than the Chinese and Japanese green teas. Again our high country green teas were less bitter and astringent than the green teas of mid and low country. This was due to the presence of excessive amounts of astringent polyphenols and relatively low amounts of amino acids. The commercial varieties of Japanese, Chinese and Sri Lanka (Ratnapura) green teas have been analysed (Wickremasinghe, 1978):

<i>Green teas</i>	<i>Polyphenols</i>	<i>Amino acids</i>
Japanese Sencha	229	21
Chinese	258	18
Sri Lanka (steam method)	413	17

(All values expressed as mg g⁻¹ dry weight)

During this study we have observed that the bitterness and astringency slightly varied when processing parameters were altered. This merits further investigation.

The appearance of the rolled leaf of the 90 cm (36") roller was found to be better than the leaf rolled in the 110 cm (44") roller. The ideal size of the roller for green tea processing has also to be investigated taking into consideration the fact that rollers work at speeds slower than 40 rpm.

The method of roll-breaking rolled leaf was not satisfactory. The frequent cleaning of the clogged roll-breaker mesh took considerable time and this disorganized the rolling programme. Suitable modifications to the roll-breaking system have to be introduced to overcome this defect.

The Walker's pressure drier was found to be unsatisfactory for drying green tea. A fair amount of dried tea particles was trapped in the space between the lowest set of drier trays and the outlet valve. This hindered the correct drying. An ECP type drier has to be tried out for drying green tea.

Drying green teas using a combination of ECP type drier and rotary drier is the standard method of the Chinese green tea preparation. By adopting this method we could improve the appearance and quality of our green teas inclusive of aroma. Even in

the Indonesian green tea factories a rotary panner or a rotary drier is preferred for the final drying of the green tea, because this helps to achieve a better curled appearance of the leaf (Bambang and Musalam, 1988). During the final firing the method of applying heat to dry the tea has a beneficial influence on quality and aroma (Yamanishi, *et al*, 1988).

The system of grading adopted was not satisfactory. This can be improved by incorporating a Chota sifter and a suitable cutting machine. The objective of investigating this modified system of Chinese green tea processing is to adopt it in our black tea factories without incurring heavy capital expenditure. Since the tea trade is more than 90 per cent involved in black tea and Sri Lanka would remain a major black tea producing country, diversification towards green tea production could only be to a small extent. Hence, an elaborate system of green tea manufacture may not be feasible. One possibility is that the excess crop obtained during the heavy cropping seasons, which the black tea manufacturing factories are unable to cope up with could be converted to green tea in some of the silent factories. It may be mentioned that at current market trends green tea fetches a higher price than black tea.

REFERENCES

- ANON. (1974). Green Tea Leaflet, Tea Board of India. 16 pp.
- COOK, E. K. (1931). A Geography of Ceylon. 360 pp.
- EDEN, T. (1976). Tea. 236 pp. Longmans, London.
- ELLIOTT, E. C. and WHITEHEAD, F. J. (1926). Tea planting in Ceylon, The Times of Ceylon Co., Ceylon.
- BAMBANG, K. and MUSALAM, Y. (1988). Indonesian green tea, manufacture and quality. Symposium on 'Recent Development in Tea Production', 315-322.
- YAMANISHI, T., MICHIKO., KOBAYASHI, A., HAMADA, T. and MUSALAM, Y. (1988). Thermal generation of aroma compounds from tea and tea constituents. ACS Symposium Series 409, 310 - 319.
- WICKREMASINGHE, R. L. (1978). Monographs on tea production in Sri Lanka, No. 7, 65 pp.