

DEVELOPMENT OF AN OPTO-CHEMICAL SENSOR FOR THE DETECTION OF Cu^{2+} IONS IN AQUEOUS SOLUTION

H.M.N. BANDARA*, J.S.H.Q. PERERA, D.T.B. TENNAKON, R.M.G. RAJAPAKSE, S.D.S. JAYATISSA, A.N. ILLANGANTILAKA AND G.R.U. JAYASURIYA

Department of Chemistry, University of Peradeniya, Peradeniya, Sri Lanka.

ABSTRACT

The construction of an opto-chemical sensor based on fibre-optics for the detection of Cu^{2+} in aqueous solution is described where, 5,6-diamino 1,10-phenanthroline immobilized on silica gel serves as complexing agent. Convenient detection of Cu^{2+} can be achieved at concentrations as low as 1 ppm. This paper also describes a fibre-optic based portable low cost visible reflectance spectrometer designed and constructed to use in conjunction with fibre-optic based opto-chemical sensors.

Key Words: Opto-chemical sensor, detection of Cu^{2+} in aqueous solutions, 5,6-diamino 1,10 phenanthroline, optical fibre visible reflectance spectrophotometer

1. INTRODUCTION

Detection and quantification of the chemical pollutants in the atmosphere and water bodies, with a view to effectively control environmental pollution has become a pressing need for the continued well-being of the society. Methods for the determination of most common pollutants are available. However, the majority of these methods suffer from disadvantages such as the requirement of sophisticated and expensive instrumentation, the use of lengthy procedures requiring long executing times and the inability to carry out *in situ* measurements. Chemical sensors provide an elegant strategy to overcome most of these difficulties. At present there is a world-wide research effort for the development of optical and electrochemical sensors.

Optical-fibre transducers are novel devices based on opto-electronics, fibre optics and optical spectroscopy [1,2]. Optical fibre light-guides have the ability to transmit light over large distances without

significant attenuation. Opto-chemical transducers offer several advantages over conventional analytical probes. Optical sensors are electrically passive, immune to electromagnetic interference, structurally flexible and are capable of operation in remote and hostile environments. Such sensors can, therefore, be used in dynamic environments irrespective of distance and severity of environment.

One of the key components in opto-chemical sensors is an appropriate complexing agent, which provides a detectable colour change upon stoichiometric interaction with the analyte. Immobilization of such complexing agents, on an appropriately transparent substrate, without sacrificing its characteristics poses a significant challenge to the researchers working on the development of opto-chemical sensors.

1,10-phenanthroline is a complexing agent used for the colorimetric determination of iron [3,4] and its alkyl- and phenyl- derivatives are used for the determination of copper [5,6].

*hmn@pdn.ac.lk

This paper describes the synthesis and immobilization of a derivative of 1,10-phenanthroline and the construction of an opto-chemical probe for the detection of Cu^{2+} ions in aqueous solutions.

Such sensors could have many applications and the realization of their full potential in field situations depends on the cost and the portability of the complete analytical assembly. This paper, therefore, also describes an optical fibre based low-cost portable visible reflectance spectrophotometer, designed and constructed in our laboratory, that can be used in conjunction with any optical fibre based sensor.

2. EXPERIMENTAL

2.1 Synthesis, characterization and immobilization of 5,6-diamino 1,10-phenanthroline

As a strategy to chemically modify 1,10-phenanthroline such that it could be chemically attached to an appropriately transparent substrate while keeping reagent's chelating ability intact, an attempt was made to introduce an amino group to the phenanthroline ring system by nitration followed by reduction. Treatment of 1,10-phenanthroline (Colourless) with a mixture of sulphuric acid and nitric acid gave a pale yellow nitro-derivative. This was then reduced using Sn/HCl affording a brown coloured product that gave a positive carbylamine test, thus confirming it as an amino derivative. The ^1H NMR spectra of both the nitro-derivative as well as the amino-derivative, showed three absorptions in the aromatic region consistent with a 5,6-disubstituted 1,10-phenanthroline.

Complex formation between the prepared amino-derivative of 1,10-phenanthroline (DAP reagent) and a range of metal ions (Fe^{2+} , Fe^{3+} , Cu^{2+} , Cu^+ , Ni^{2+} , Cd^{2+} , Pb^{2+} , Al^{3+} and Cr^{3+}) was studied by mixing aqueous solutions of these ions with the DAP reagent dissolved in acetone. Solutions of constant ionic strengths were tested at different pH values. It was found that the reagent was remarkably sensitive to ppm level concentrations of Cu^{2+} , forming pink coloured solutions. The sensitivity was found to increase in the presence of NH_4Cl in the solution and the optimum pH for complex formation was found to be around 6. The pink coloured complex shows

absorption maximum at 525 nm with an extinction coefficient of $32540 \text{ dm}^3 \text{ mol}^{-1} \text{ cm}^{-1}$. The linear range of concentration of Cu^{2+} against absorbance plot extends down to 1 ppm of Cu^{2+} with a sensitivity of $5 \times 10^{-3} \text{ ppm}^{-1}$.

The stoichiometry of the reaction between the DAP reagent and Cu^{2+} , studied by the method of continuous variation using UV-Visible Spectrophotometry, was found to be 2:1 (DAP: Cu^{2+})

The potential of the DAP reagent as a sensor material was then investigated by immobilizing it on XAD ion exchange resin as well as on chromatographic grade silica. The immobilization of the reagent on the ion exchange resin to obtain resin beads physically coated with the sensor material, was achieved by wet impregnation of the reagent from an acetone solution on the washed and dried resin followed by the slow evaporation of the solvent. The material obtained produced visible colour changes with Cu^{2+} in aqueous solutions.

The immobilization of the sensor on chromatographic grade silica was achieved through chemical means. Here, oven dried chromatographic grade silica was first reacted with thionyl chloride to convert the surface $-\text{OH}$ groups into $-\text{Cl}$. The resultant material was then thoroughly washed with dry dichloromethane to obtain surface modified silica. This was then treated with the DAP reagent in dry acetone. After draining the excess solution the material obtained was washed and dried. The product obtained was yellow in colour and the coating, chemically attached to the surface, resistant to a range of solvents, more importantly to mildly acidic solutions. This material, which produced visible colour changes with ppm range aqueous solutions of Cu^{2+} , was used in the construction of the opto-chemical probe.

2.2 Instrumentation

2.2.1 Construction of the probe.

Silica gel coated with the sensor material enclosed in a mesh was attached to a bifurcated optic fibre bundle enclosed in a Teflon sheath to construct the probe. A schematic diagram of the constructed sensor probe is given in the Figure 1

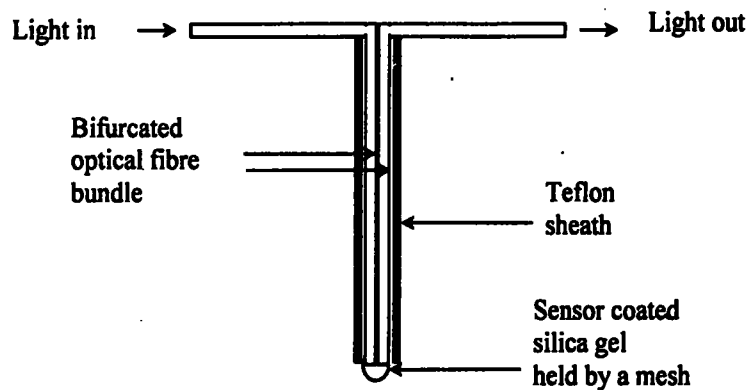

Fig. 1 A schematic diagram of the opto-chemical sensor probe made of a bifurcated optical fibre bundle in contact with 5,6-diamino-1,10-phenanthroline bonded silica gel.

2.2.2 Optic Fibre Visible Spectrophotometer

A low cost scanning type spectrophotometer was constructed for the specific purpose of recording reflection spectra using the probe,

described earlier, containing sensor material and coupled to the instrument by means of optical fibres. A block diagram of the instrument is given in Figure 2.

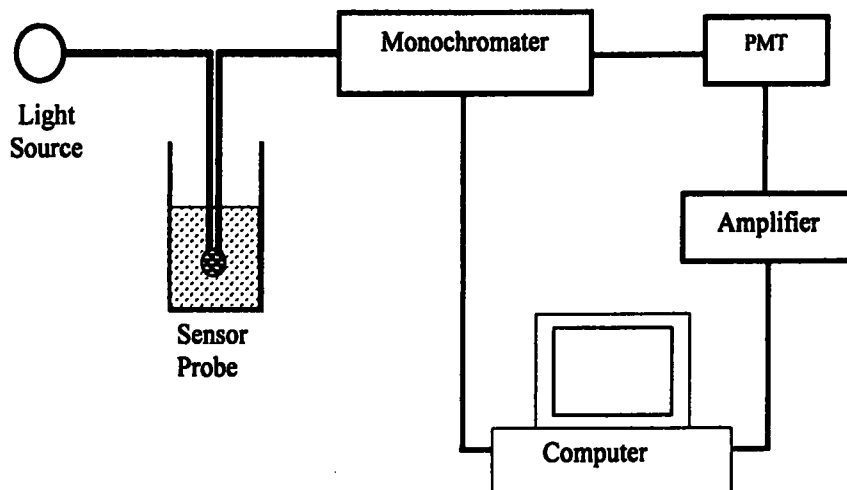

Fig. 2 A block diagram of the optic fibre visible reflectance spectrophotometer

The light source used in the construction is a 10 W tungsten-halogen lamp. Light from the source is carried to the probe through one arm of a bifurcated optic fibre bundle. The spectral information in the reflected light from the probe is carried to the monochromator through the other arm of the optic fibre bundle. The monochromator consists of a 1200 lines/mm holographic grating driven by a stepper motor interfaced to a computer. The detector is a photomultiplier tube (PMT). The PMT signal is amplified by an operational amplifier. The amplified analog signal is then sent to an A/D converter through a sample-and-hold IC. The digital real-time output from the A/D converter is stored in a computer as the scan progresses. A chopper in the optical path coupled to a lock-in amplifier allows the measurement of even the very weak signals without interference from stray light. A sample of spectra recorded for aqueous Cu^{2+} solutions with concentrations in the ppm range is given in the Figure 3.

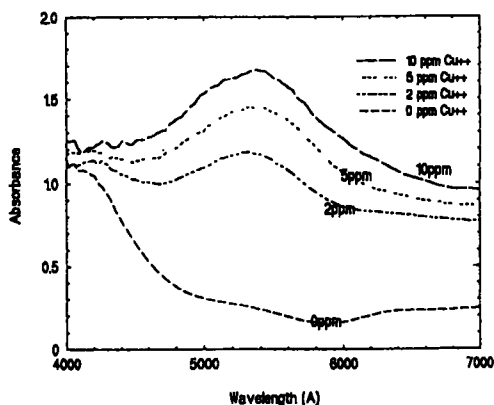

Fig. 3 Visible reflectance spectra of aqueous Cu^{2+} ion solutions recorded using the optical fibre based scanning visible spectrophotometer and the 5,6-diamino,1,10-phenanthroline sensor probe

3. RESULTS AND DISCUSSION

The sensor material (DAP reagent) prepared by the nitration of 1,10-phenanthroline followed by Sn/HCl reduction may be concluded to be 5,6-diamino, 10-phenanthroline from the ^1H NMR spectra the nitro-derivative as well as the amino-derivative which showed three absorptions in the aromatic region. The ^1H NMR signals, which confirm that the nitrated derivative of 1,10-phenanthroline has a symmetric structure, are consistent with a 5,6-disubstituted 1,10-phenanthroline. (5th and 6th positions of 1,10-phenanthroline are also the most reactive towards electrophilic substitution)

The sensor material prepared in this work appears to be a highly selective complexing agent for Cu^{2+} . The pink coloured complex formed by 5,6-diamino,1,10-phenanthroline with Cu^{2+} exhibits a 1:2 (metal : ligand) stoichiometry. The complex shows an absorption maximum at 525 nm and the large extinction coefficient of $32540 \text{ dm}^3 \text{ mol}^{-1} \text{ cm}^{-1}$ suggests an absorption due to a charge transfer transition. Methods currently available for the colorimetric determination of copper include the use of 2,9-dimethylphenanthroline (Neocuproine) [5,6] and 2,9-dimethyl-4,7-diphenyl-1,10-phenanthroline disulphonic acid (Bathocuproinedisulphonic acid) [7]. These methods require the pre-reduction of cupric ions to cuprous ions and cumbersome extraction of the coloured complex into organic solvents such as chloroform. The analytical method used in the present work does not involve such pre-reduction and solvent extraction processes and therefore affords a convenient method for quantification of Cu^{2+} in aqueous solutions at concentrations as low as 1-2 ppm. To our knowledge this is the first report of a diamine derivative of 1,10-phenanthroline used in the detection of Cu^{2+} .

The optical fibre based visible spectrophotometer constructed to use in conjunction with the opto-chemical probe provides reproducible reflectance spectra of the copper-5,6-diamino,1,10-phenanthroline complex formed at concentrations as low as 2 ppm of Cu^{2+} as shown in Figure 3. This spectrophotometer can conveniently record reflectance spectra of any surface, in the visible range, using a simple probe made of an optical fibre bundle in a Teflon sheath. The entire operation of the

spectrometer is computer controlled through an interface and software developed in our laboratories.

4. CONCLUSION

5,6-diamino-1,10-phenanthroline was prepared by the nitration of 1,10-phenanthroline followed by Sn/HCl reduction. This brown coloured material complexes highly selectively with aqueous Cu^{2+} ion solutions of concentrations as low as 1 ppm, giving a pink coloured complex with an absorption maximum at 525 nm and an extinction coefficient of about $32,000 \text{ dm}^3 \text{ mol}^{-1} \text{ cm}^{-1}$. The linear range of the Beer-Lambert plot extends to concentrations as low as 1 ppm in Cu^{2+} . 5,6-diamino-1,10-phenanthroline can be physisorbed on materials such as the XAD2 ion exchange resin. It could also be chemically bound on surface-chlorinated chromatographic grade silica without the loss of chelating ability.

5,6-diamino-1,10-phenanthroline chemically bonded to silica was used to construct an opto-chemical probe which could be used to record a reflection spectrum of the copper-5,6-diamino-1,10-phenanthroline complex at copper concentrations as low as 2 ppm. This is the first report, to the authors' knowledge, of the use of 5,6-diamino-1,10-phenanthroline for the detection of Cu^{2+} which affords a convenient method for the colorimetric detection of Cu^{2+} without pre-reduction and solvent extraction.

A low cost portable optical fibre based scanning visible spectrophotometer, which has the ability to record reflectance spectra, was constructed to use in conjunction with opto-chemical probes.

5. ACKNOWLEDGEMENT

Authors wish to thank the National Science Foundation of Sri Lanka (formerly Natural Resources, Energy and science Authority of Sri Lanka) for the generous Research Grant, which made this project a reality.

REFERENCES

1. R. Narayanaswamy, *Analyst* **118** (1993) 317.
2. M. N. Taib, R. Narayanaswamy, *Analyst* **120** (1995) 1617.
3. J. A. Ryan, G. H. Botham, *Anal. Chem.* **22** (1949) 1470.
4. D. H. Caldwell, R. B. Adams, *J. Amer. Water Works Assoc.* **38** (1946) 727.
5. J. W. Fulton, J. Hastings, *Anal. Chem.* **28** (1956) 174.
6. G. F. Smith, McCurdy, *Anal. Chem.* **24** (1952) 371.
7. Blair, D., and Diehl, H., *Talanta* **7** (1961) 163.