

*J. Natn. Sci. Coun. Sri Lanka 1985 13 (1) :*

## DESIGN REQUIREMENTS AND DIMENSIONS FOR A COMFORTABLE WORK SEAT FOR SRI LANKANS

J. D. A. ABEYSEKERA\*

*Division of Occupational Hygiene, 97, Jawatte Road, Colombo 5, Sri Lanka.*

*(Date of receipt : 5 June 1984)*

*(Date of acceptance : 14 May 1985)*

**Abstract:** Uncomfortable workseats are a common sight in many work places today. Sitting at work on a comfortable seat helps to relax the body and reduce energy consumption, but on the other hand prolonged sitting slackens abdominal muscles and may cause backache. An optimum work seat can be made if proper medical and ergonomic ideas are applied in the design. The data on body sizes of the users are important to design an optimum work seat. A National Anthropometric (body sizes) Survey has provided this data. Based on this data, recommended dimensions for a work seat are as follows :

	Males	Females
Seat Height (from floor)	39.5 cm	36.4 cm
Back rest Height (from seat)	44.9-46.9 cm	40.4-42.4 cm
Back rest Breadth	37.0 cm (29.0 cm minimum)	33.3 cm (25.3 cm minimum)
Lumbar support Height (from seat)	16.4-26.5 cm	16.1-25.8 cm
Seat Width	39.7 cm (27.7 cm minimum)	40.0 cm (28.0 cm minimum)
Seat Depth	36.3-41.3 cm	34.2-39.2 cm
Arm rest Height (from seat) (for armed chairs)	19.8 cm	18.5 cm

The other important recommendations are a backward tilt of the seat surface of  $14 - 24^\circ$  to the horizontal, to prevent buttocks sliding forwards, a lumbar support on the back rest and an inclined back rest of  $105 - 110^\circ$  to seat or  $110 - 130^\circ$  to the horizontal.

### 1. Introduction

Many problems of mismatch between the man and his work tools and machines including furniture are a common sight in Sri Lankan factories and work places. Discomfort, body pain, inefficiency, delay and wastage are some results of these wrongly designed work aids.

A work seat may be called an essential requirement for most workers either to perform work with less fatigue or as an aid for relaxation. It also improves their well-being and efficiency if people sit at their work. Static muscular effort which is required for a standing person ceases when the

\* Present address - Department of Human Work Sciences, University of Lulea, Sweden.

person sits down. The other advantages of sitting are, it takes the weight off the legs, reduces energy consumption and avoids unnatural body postures. There are also drawbacks such as slackening of abdominal muscles due to prolonged sitting and curvature of spine that may cause inter-vertebral disc pressure<sup>4</sup> resulting in backache. In order to maximise the advantages and to minimise the drawbacks it is important to apply medical and ergonomic ideas in the design of seats for work.

In the application of ergonomic principles in the design of a work seat, greater emphasis has to be given to the body sizes of the users.

## 2. Method

A National Anthropometric Survey<sup>1</sup> (Body Sizes Survey) was conducted in Sri Lanka on 438 male workers and 288 female workers. The subjects taken for the measurements included workers from 80 work establishments from 24 districts in Sri Lanka.

A standard anthropometer and an adjustable chair were used to take most measurements. Vernier calipers and tapes (canvas and metallic) were used to take few measurements. Measurements were carried out by specially trained technicians and included among other measurements all important dimensions required to design a seat.

The anthropometer is a counter recording instrument which can be effortlessly operated from the tips of its branches. This instrument gives a direct and accurate reading, to the nearest millimeter over a range of 50 mm. Each instrument has straight and recurved branches and beam extensions for the measuring of heights of up to 3 meters.

Each subject was required to sit on the adjustable chair and the seat was adjusted till the seat gave the worker maximum comfort.

The seat gives maximum comfort when the subject sits comfortably erect on the adjustable chair with the trunk straight, the back of the head and buttocks pressing firmly against the walls of the chair. The stool height is adjusted so that the upper part of the leg is horizontal to the floor. The lower part of the thigh at the back of the knee not pressing on the edge of the chair but leaves a small space between the leg and the chair, the feet flat on the floor and the shins vertical.

## 2.1 Description of Measurements and their significance and recommended Measurements

**2.1.1 Seat Height :** This is the vertical height of the sitting surface from the floor, when the subject is comfortably seated erect. (Figure 1)

Any good design should accommodate about 90% of the population. It would be practically difficult to accommodate the extremes of the population, i.e. the 5% very short people and 5% very tall people. Therefore in deciding the height of a seat the mean sitting height of the population is the most convenient height, if the height is fixed (not adjustable). On the other hand if the seat is adjustable the maximum height should be the height of 95th percentile of the population and the minimum height should be the height of 5th percentile of the population. If however a high seat is required depending on the operating height, a foot rest has to be provided to counter-balance the extra height. Similarly in deciding the seat height, another factor that has to be taken into consideration is the shoe height (which is in the range of 10 – 20 mm) that has to be added to the seat height. Therefore the mean sitting height plus 15mm (for shoes) can be recommended as the seat height.

**2.1.2 Back rest Height :** The part of the human anatomy between the lowest ribs and upper hip bones is suspended by the vertebral bones and is called the lumbar region. For the back to be relaxed and anatomically convenient, this most vulnerable area of the spine viz: the lumbar region, has to be supported by the back rest of the seat. To relax the back muscles where occasional leaning back is necessary, a high back rest, a clear 10 – 12 cm lower than the sitting shoulder height is recommended.

- i. **Lowest rib bone height, sitting:—** Sitting comfortably erect. Measurement from floor to the bottom of the lowest left rib. The lowest left rib is traced by palpating the rib box of the subject. (Figure 2)
- ii. **Upper hip bone height, sitting:—** Sitting comfortably erect. Measurement from floor to the uppermost point of the left hip bone. The hip bone is traced by palpating. (Figure 3).
- iii. **Shoulder height, sitting:—** Sitting comfortably erect. Measurement from floor to center point between base of neck and acromial. (Figure 4)

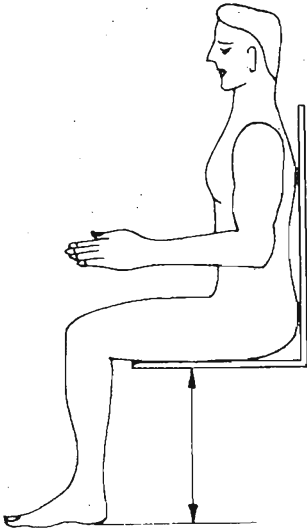

Figure 1. Seat Height

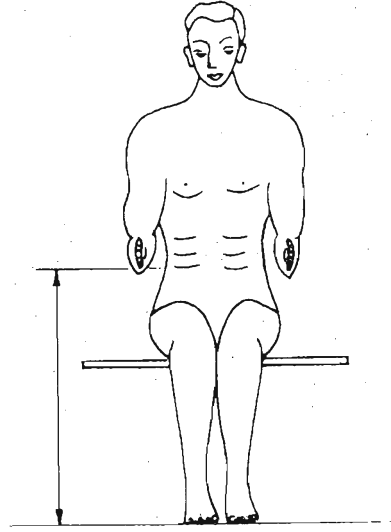

Figure 2. Lowest Rib Height, Sitting

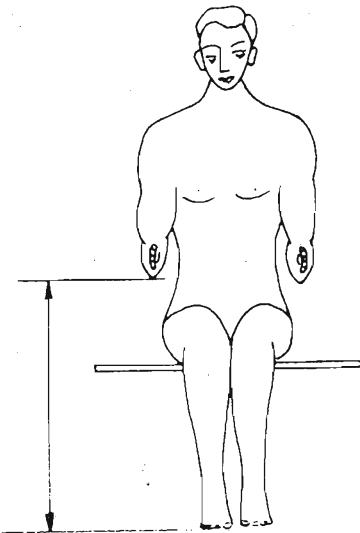

Figure 3. Upper Hip Bone Height, Sitting

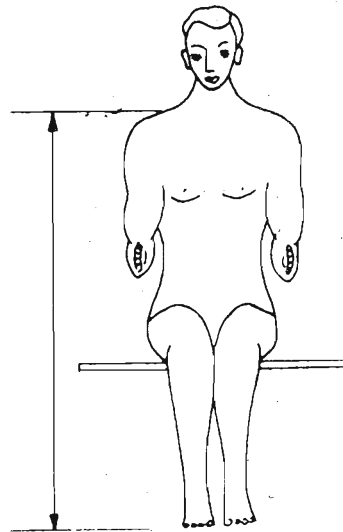

Figure 4. Shoulder Height, Sitting

**2.1.3 Back rest Breadth :** The back rest to be able to accommodate 90% of the population, it is necessary that 95th percentile chest breadth of the population is taken which would be the minimum requirement. However it is recommended that 8 cm are added to the 95th percentile chest breadth to accommodate the area of the back just above the chest and just below the shoulders. The 8 cm was arrived by taking into consideration the shoulder breadth (or biacromial breadth) measurement. (Mean for males – 36.8 cm and mean for females – 33.1 cm).

- (i) Chest breadth :— Measurement taken from the front side of the subject, the distance between the widest point across the chest. (Figure 5).
- (ii) Biacromial breadth :— Measurement with caliper tips of the anthropometer in firm contact with outer edges of acromial process. (Figure 6).

**2.1.4 Arm rest Height :** The most comfortable position anatomically of the arm rest in a chair is the elbow height, when comfortably seated.

- (i) Elbow rest height, Sitting :— Sitting comfortably erect, elbow held lightly against sides with forearms horizontal to the floor. Measurement from floor to the lowest point on the left elbow. (Figure 7).

### **2.1.5 Seat Surface Dimensions**

- (1) Hip width :— Measurement with caliper tips of the anthropometer in firm contact with the widest points of the hip bones of the two sides. (Figure 8).

The width of the seat to be able to accommodate 90% of the population, it is necessary that the 95th percentile hip width of the population is taken, which will be the minimum requirement. To accommodate the upper legs at different sitting positions, it is recommended that the width of the seat should be 95th percentile dimension of hip width plus 12 cm. The additional space would also allow to accommodate the upper legs at sitting positions with expanded legs. This additional space (12 cm) was arrived by making observations of common sitting postures of workers.

- (ii) Buttock to back of knee sitting:— Sitting comfortably erect. Measurement from end wall to furthest point in back of knee. (Figure 9).

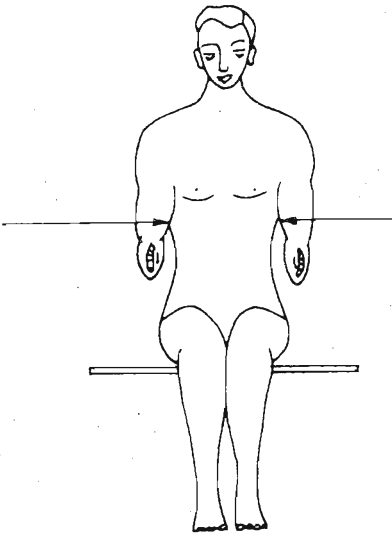

Figure 5. Chest Breadth

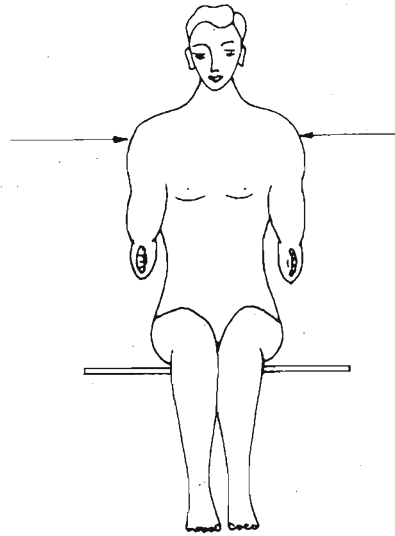

Figure 6. Biacromial Breadth

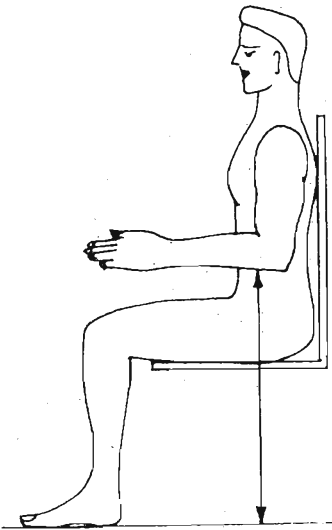

Figure 7. Elbow Height, Sitting

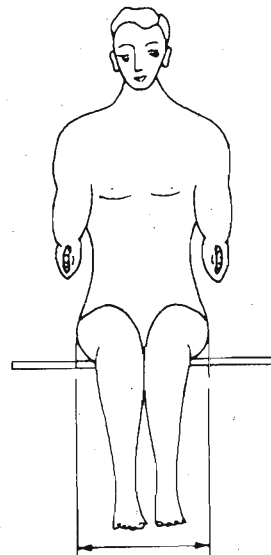
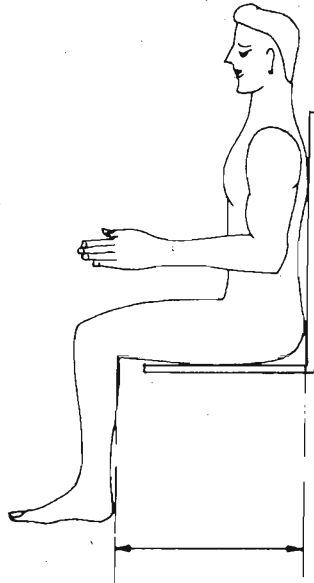

Figure 8. Hip Width



**Figure 9. Buttock to Back of Knee, Sitting**

The depth of a seat should accommodate comfortably the portion of the leg between the buttock and the back of the knee. If the back of the knee presses or touches the edge of the chair or if the depth of the seat is insufficient to accommodate at least 90% of the lower portion of the upper leg, the seat could be uncomfortable. Therefore the mean of this measurement obtained in the national sample would be the maximum depth that could be recommended for a standard comfortable seat. The minimum depth can be 5 cm less than the mean.

#### **4. Results**

The results obtained from the national survey are shown in Table 1.

Table 1 — Results of Body Dimensions taken with the Subjects Seated Comfortably

	Height of seat		Lowest rib Height, Sitting (from floor)		Upper Hip Bone Height, Sitting (from floor)		Shoulder Height (from floor) Sitting		Chest Breadth		Biacromial Breadth		Elbow Height, Sitting (from floor)		Hip Width		Buttock to back of knee, Sitting	
	M	F	M	F	M	F	M	F	M	F	M	F	M	F	M	F	M	F
Number of Subjects	434	285	435	288	436	287	434	288	436	288	434	288	436	287	436	285	436	288
Mean	380	349	645	607	544	510	949	873	249	225	368	331	578	534	250	246	459	446
Standard Deviation	29	24	45	37	43	36	51	45	27	19	23	18	52	39	18	22	31	35
Standard Error	1.39	1.42	2.16	2.18	2.06	2.13	0.24	0.27	0.13	0.11	0.11	0.11	2.49	2.30	0.86	1.30	1.48	2.06
Coefficient of Variance (Percentages)	7.6	6.9	6.9	6.0	7.8	7.1	5.3	5.1	10.7	8.5	6.4	5.6	8.9	7.4	7.1	9.0	6.7	7.9
Range	208 476	229 419	505 1021	489 757	402 695	368 621	726 1221	618 1003	125 464	122 310	256 430	287 383	462 1006	413 666	194 312	186 355	233 612	206 522
5th Percentile	338	316	585	550	485	457	876	811	216	199	331	300	509	470	224	212	416	400
95th Percentile	423	391	715	669	619	571	1025	940	283	252	402	361	663	600	280	281	507	494

All measurements in millimeters.

M — Males.

F — Females

Note: Unreliable measurements have been deleted and certain measurements have not been recorded on some subjects. Therefore the number of subjects varies for different measurements.

## 5. Discussion

The part of the body that is affected mostly by stressful work postures is the back. In many sitting positions, the spine and the muscles of the back are not relaxed but stressed in various ways.

An intervertebral disc is some sort of a cushion that separates two vertebrae and helps to give flexibility to the spine. Degeneration of the intervertebral discs impair working of the vertebral column. Unnatural postures and uncomfortable seats speed up deterioration of the discs.<sup>2, 5, 6</sup>

Research carried out by Nachemson,<sup>4</sup> on 9 healthy subjects on effects of various bodily postures on disc pressure has indicated the following results.

Body Posture	Disc Pressure between 3rd and 4th lumbar vertebrae expressed as a percentage of pressure when standing erect
Standing Erect	100
Lying flat on the back	24
Sitting, trunk erect	140
Sitting, bent forwards	190

These results clearly show that disc pressure is greater when sitting than when standing. Further it indicates that a better sitting position is when the trunk is erect than bent forwards.

The most vulnerable part of the spine is the lumbar region as this part suspends between the upper part of the body (heavy) encasing the rib box and the lower part (lighter) starting from the hip bone. Therefore it is most important that this lumbar region has to be supported by the back rest. A lumbar pad of 5 cm thickness is preferable to a flat back rest.<sup>2</sup>

Investigators Anderson et al,<sup>2</sup> Nachemson,<sup>4</sup> and Yamaguchi et al,<sup>6</sup> have studied the effects of seat angle and the shape of the back rest, on disc pressure. The experiments have revealed that the best conditions for relaxation of the spine have been provided by a seat angle to the horizontal of 10°–14° and an angle between the seat and the backrest of 115°–120°.

Grandjean et al,<sup>3</sup> has studied different seat profiles on a large number of subjects and obtained their subjective impressions. He has found that a seat profile which produces only a low pressure in the intervertebral disc and requires very little static muscular effort, is also the one that causes the fewest aches and pains.

Therefore in designing a work seat, which is good medically and ergonomically and taking these researches as a whole, the following recommendations are made.

- (a) Seat surface should be tilted backwards so that the buttocks will not slide forwards. A tilt of  $14 - 24^{\circ}$  to horizontal has been recommended.
- (b) Backrest should be high which is slightly concave to the front at its top end, and distinctly convex in the lumbar region. The backrest should also be inclined at the following angles.
  - i. to the seat  $105 - 110^{\circ}$
  - ii. to the horizontal  $110 - 130^{\circ}$

The above additional design requirements could be made applicable to a comfortable work seat for Sri Lankans.

#### A prototype Work Seat

In considering the above discussion and based on the data provided by the Anthropometric Survey, the following prototype work seat is recommended. (Figures 10 and 11). Dimensions for seats to be used by males as well as females in Sri Lanka are indicated.

A table to be used with this chair should have a height from the floor to the bottom of the table of 55.8 cm for males and 51.4 cm for females and from floor to the top of table of 59.3 cm for males and 54.9 cm for females. It is also recommended that if a chair is to be provided with arms, the arm rest height from seat should be 19.8 cm for males and 18.5 cm for females. The mean elbow height (seated), has been considered to be the most convenient level for both the table top height (working height) and arm rest height. (1.5 cm for shoes are added to the mean elbow height measurement).

This study however did not examine the prototype chair recommended, subjectively. The seat material characteristics and the effects of the environment are other factors that have to be considered when conducting subjective assessments.

**Fig.10** WORK SEAT (Side View)

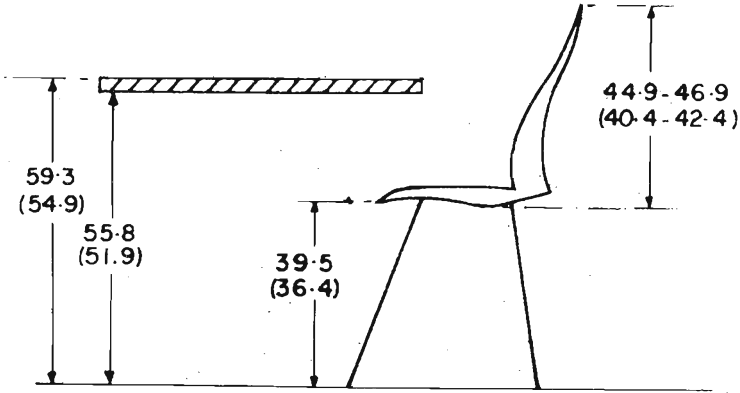

**Fig.11** WORK SEAT (Front View)

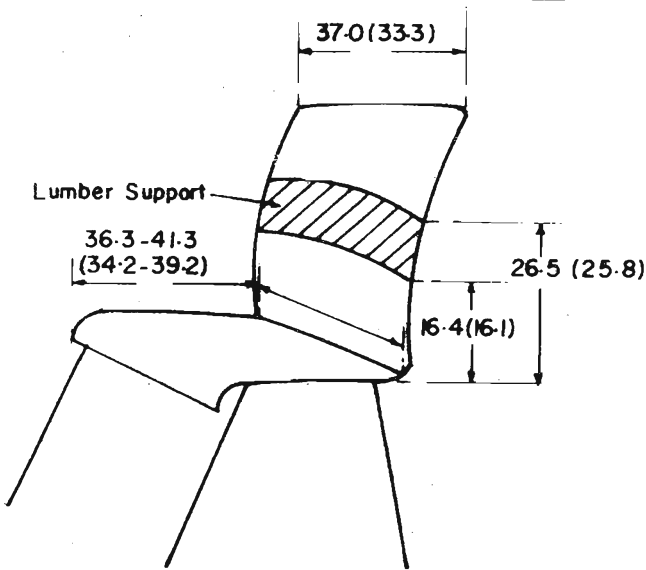

All Measurements in Centimeters

### Acknowledgements

The author is grateful to the Natural Resources, Energy and Science Authority of Sri Lanka (NARESA) for funding the National Anthropometric Survey of workers. Thanks are also due to Mr. Neil Wimalaratne, Mrs. W. M. M. Ratnayake and Mr. C. K. Dissanayake of the Division of Occupational Hygiene for their skillful technical help.

### References

1. ABEYSEKERA, J. D. A.. Report of the National Anthropometric Survey of Workers, Sri Lanka, 1981/82. (A Report submitted to the Natural Resources, Energy and Science Authority of Sri Lanka.)
2. ANDERSON, B. J. G. & ORTENGREN, R., (1974). Lumbar disc pressure and myoelectric back muscle activity during sitting. Studies on an office chair, *Scan. J. Rehabilitation Medicine* 3 : 115 - 121, 104 - 114, 3: 122 - 128, 128 - 135.
3. GRANDJEAN, E., HUNTING, W., WOTZKA, G. & SCHARER, R. (1973). An ergonomic investigation of multi-purpose chairs. *Human Factors* 15: 247 - 255.
4. NACHEMSON, A. (1974). Lumbal intradiscal pressure. Results from in vitro and in vivo experiments with some clinical implications. 7. *Wiss Konf. Deutcher Naturforscher and Aerzte*. Springer, Berlin, Heidelberg, New York.
5. NACHEMSON, A. & ELFSTRON, G. (1970). Intravital Dynamic Pressure Measurements in Lumbar Discs. *Scan. J. Rehabilitation Medicine, Supplement* I. Almqvist and Wiksell, Stockholm.
6. YAMAGUCHI, V., UMEZAWA, F & JSHINADA, Y. (1972). Sitting posture: an electromyographic study on healthy and notalgic peoples. *J. Jap. Orthop. Ass.* : 46: 51 - 56.