

REVIEW**INFORMATION TECHNOLOGY DEVELOPMENT IN SRI LANKA**

A. S. INDURUWA*

*Technical Advisory Unit, Computing Laboratory, University of Kent, Canterbury CT2 7NF, England.**(Received: 02 August 1998 accepted: 01 December 1999)*

Abstract: It is easy to introduce new and emerging technologies such as Information Technology (IT) to any developing economy, with or without the assistance of developed economies. What is important however, is the ability of a country to sustain the technological developments for economic growth. This ability depends on key areas such as Human Resources Development, Infrastructure Development, and Policy Framework Development and their implementation.

Computers were introduced in Sri Lanka in the late sixties, when the State Engineering Corporation first followed by the Department of Census, acquired computers. Yet almost after 30 years Sri Lanka has not been able to make an impression in the global IT scene as a major consumer or as a provider. This paper outlines global trends and examines some of the issues relevant in the Sri Lankan context. It also describes the development of LEARN, the pioneering Internet initiative for the academic and research community in Sri Lanka.

Key Words: Computer science teaching, information technology, Internet, LEARN, research information infrastructure, socio-economic development, telecommunications.

INTRODUCTION

The world has so far witnessed two phases of economic revolution, namely agricultural and industrial, resulting in economic growth in countries which actively exploited them thus creating a divide between the so called developed and the developing worlds. Today the world is witnessing the third phase of these revolutions, based on *Information Technology (IT)*. The significant point is that any country in the world, irrespective of their present state of development, can participate in this revolution and derive economic and social benefits from it. A developing country such as Sri Lanka with its traditionally high literacy rate coupled with low labour costs has much to gain from the IT revolution. IT revolution is expected to bring economic growth to participating countries and reduce the gap between the developed world and the developing world. Countries that do not actively participate in this exercise however, will face the danger of exclusion from the economic development activities of the rest of the world, thereby increasing their dependency on the economically strong countries for their survival.

* The author is the founding Head of the Department of Computer Science & Engineering, University of Moratuwa and founder of Lanka Experimental Academic and Research Network (LEARN), the Internet for academic and research community in Sri Lanka.

Sri Lanka must embrace this opportunity now and effectively exploit the economic and social benefits that are associated with the emerging Information Society¹. As a nation, it must quickly master new knowledge to survive in a fiercely competitive global market place. This paper looks at the growth of Information Technology in Sri Lanka and attempts to place it in the context of global development trends. It also focuses on some of the key areas that require serious attention of the policy makers and implementers, if Sri Lanka is to gain the status of a newly industrialised economy in the next century.

IT in the Global Scene

The growing use of IT in all aspects of everyday life in developed countries has made the IT industry to be one of the fastest growth areas in the world. There is no single application area where IT is not used today, whether it be education, health, social security, banking and commerce, entertainment, travel and tourism, manufacturing industry, defense or scientific research. This is primarily because IT makes it possible for almost every kind of information to be stored, accessed, processed and transmitted digitally in electronic form, and without reference to traditional "print on paper" media.

As the frontiers in IT move on, less developed economies are offered a chance to join the IT industry. It must be emphasised that the power and facilities unleashed by IT can be used by a developing country to reach the frontiers of technological development and attain the status of an economically developed country.

Importance of Human Resource Development

Human Resource Development (HRD) plays a vital role in sustaining the technological and economic development in any country. This undertaking is made even more difficult due to the fact that training programmes associated with IT human resources development have to keep pace with the fast changing technology to prevent them from becoming obsolete and useless². The fast changing technology and work methods in the work place also require retraining the work force continually at all levels from senior management downwards. This puts a great burden on the institutes providing the training, as well as on the industry itself which is required to keep the work force up-to-date.

To meet successfully the challenges of HRD it is necessary to provide a multitude of training opportunities, both long term and short term, with some even tailored to meet specific short term requirements. This latter category includes specialised training programmes, for example those designed and offered by the University of Colombo to unemployed or underemployed graduates in almost all disciplines with a view to equipping them with necessary IT skills and making them better suited for employment in the IT industry.

The education planners in Sri Lanka must recognise that there is a large unsatisfied world wide demand for suitably trained IT personnel and Sri Lanka is bound to lose a significant fraction of its trained IT manpower due to this. This will place an extra burden on a small and developing economy like Sri Lanka that has always tried to strike a balance between supply and demand within the country.

Large countries such as India take a different view in this respect. Educational institutions in the state sector as well as in the private sector are encouraged to train as many IT literate students as they can with the hope that a natural equilibrium would be reached.

IT skills and employability

IT has already made a significant impact on jobs across all industries; it will continue to do so in the foreseeable future. Today it has come to a point that IT skills are no longer the preserve of programmers and systems analysts; they are needed by all. Even in developed countries, 64% of employers who report a *skills gap* have cited computer literacy as a key skills shortfall. Today it has become important for both the employers and employees to recognise that IT, along with *communication* and *numeracy*, is a skill which must be acquired, not just in relation to a specific job, but in order to see us through the whole of our working life. However, unlike communication and numeracy, IT skills require constant development in order to keep pace with the rapid changes in the way IT is applied in industry.

In the UK, it has been agreed that skill acquisition must start in school and not just in the workplace. Consequently it is the UK government's policy to ensure that children in school learn IT skills. The National Curriculum sets out programmes of study and attainment targets that enable children to develop their ability to use IT tools and networked information resources. A programme of this nature requires large investment to supply up-to-date software and hardware and properly trained teachers who would integrate IT into their own teaching practices and materials. With a total investment of more than £ 1 billion since 1979, the UK has achieved a level of 1 PC (*Personal Computer*) to every 8 children in secondary schools, and at least 1 PC in every primary school with an average of 10 PCs per school. Today almost 66% of the U.K. homes have a PC compared to 45% just 2 years ago.

Comparable resources have to be provided to these youth, who had already acquired sufficient IT skills in school, when they enter the universities. In a recent Report to the UK government, Sir Ron Dearing has recommended that there must be a PC for every 5 students in the Higher Educational institutions³. This is a difficult target to meet even for a country like the UK. At the moment however, a PC is available for every 8-15 students in the universities, on average.

World-wide delivery of multimedia information in real time

The universal acceptance of the World Wide Web (WWW)⁴ as a source of information and the delivery of that information in multimedia format using the Internet and its underlying protocols have required the expansion of data communication infrastructure both in terms of coverage and available bandwidth. It is estimated that by 2005 there will be 400 million users of broadband services, a significant number of whom will prefer to use a satellite system primarily due to their life style.

The developed countries have been successful in deploying various transmission technologies capable of high bandwidth multimedia delivery to any one who needs it, be it for private or for business use. There are a number of multi-billion dollar initiatives that aim to provide world wide coverage using Low Earth Orbit (LEO) satellite technology combined with terrestrial radio and landline technologies. These are worth a special mention as they will have an unprecedented impact on developing countries and especially their rural sectors.

The Iridium system⁵ is a global wireless communication network based on a constellation of 66 LEO satellites (a total of 72 satellites in orbit with 6 spares) combined with terrestrial wireless, land based cellular and public landline networks to enable subscribers to communicate using handheld telephones and pagers virtually anywhere in the world. It is arguably the first global Personal Communication System (PCS) designed to provide satellite based personal mobile telephone services such as voice, data, facsimile, electronic mail, etc. and came into operation in November 1998 at a total project cost of US\$ 5 billion. Globalstar⁶ costing US\$ 3.9 billion is a similar initiative using only 48 LEO satellites (56 in orbit with 8 spares) that came into operation in October 1999. Both these systems essentially extend the concept of popular cellular mobile phone to *satellite phone*, also known as *space phone*.

SkyBridge system⁷ is expected to be the first operational constellation of 80 satellites that will provide global access to multimedia interactive broad band communication services to users anywhere on earth, except the polar regions. SkyBridge costing US\$ 4.2 billion is targeted to be operational in the first year of the new century and to be fully operational by 2002.

Teledesic⁸ is yet another LEO satellite constellation comprising 288 satellites (300 in orbit with 12 spares), designed to support data rates in excess of 500 Mbps to and from user terminals. Implemented at an estimated cost of US\$ 9 billion, with Microsoft Chairman Bill Gates as a founding investor, and dubbed the "*broadband Internet in the sky*", Teledesic will support bandwidth-on-demand, allowing users to request and release link capacity as needed thereby enabling users to pay for the capacity they actually use. This feature in turn will enable the network to support

a much higher number of users simultaneously. The large number of active satellites in orbit will ensure that from anywhere on earth a Teledisc satellite can be seen nearly directly overhead and that usually two but sometimes three and up to four satellites will be in view of a user and a gateway at any time providing a significant coverage overlap. Teledisc is targeting to begin service in 2004.

Although it is believed that satellites will never be the dominant means of providing communication services, there is a real cost advantage in satellites when it comes to delivering broadband services to suburban and rural areas which otherwise have to be serviced using traditional transmission technologies at a much higher cost⁹. In recognising this cost advantage a number of projects similar to the ones described above are currently being formulated.

Regional IT initiatives and their relevance to Sri Lanka

In the quest to become champions in IT, Sri Lanka finds fierce competition from many countries in the region¹⁰. Some countries have moved forward with such courage and determination and find themselves in the forefront. Among them are Japan, Korea and Taiwan. These economies have always concentrated on the manufacturing side of IT and have not shown particular strengths in the software industry. This is primarily because of the slight disadvantage in terms of their ability to work in English, the internationally dominant language in the IT industry. The current indications are that they will overcome this shortfall in a few years. However the main competition to Sri Lanka at the present moment is only from a few countries in the region. Therefore it is important and interesting to examine to what extent or depth the other countries in the region hope to exploit IT for sustainable economic growth.

Countries such as India, Malaysia, Singapore and Sri Lanka enjoy an advantageous position in this regard and can dominate the software industry in the region. Already India, Malaysia and Singapore have set IT led development goals for the first two decades of the 21st century. This means that it will become a major challenge for Sri Lanka to capture a sizeable share of the world software market against this competition. However the world software market is so huge that there can be a reasonable share for every major player. What is important then is to identify niche areas to suit a country's strengths and exploit them fully. A stable politico-economic environment complete with adequate legal protection for copyright, intellectual property, trade and commerce, finance and banking, and suitably developed advanced communications, transport and other service infrastructure, however form the basis of a minimum prerequisite.

Having recognised the above, many countries have drawn up very comprehensive IT development strategies. For example, Singapore has outlined in 'IT 2000', its vision to become an *Intelligent Island* by the turn of the century¹¹. Yet

another powerful policy pronouncement is that of Malaysia's 'Vision 2020' aimed at becoming a fully developed, matured and knowledge rich society by year 2020¹². As a first step Malaysia is in the process of developing a Multimedia Super Corridor (MSC), an integrated environment with all the unique elements and attributes necessary to create the perfect global multimedia climate. Moreover Malaysia expects to help world leading companies to test the limits of technology and to prepare themselves for the future.

Through this effort Malaysia hopes to become an *Island of Excellence*, with multimedia centric capabilities, technologies, infrastructure, legislation, policies and systems for competitive advantage.

The Multimedia Super Corridor is expected to bring together four key elements:

- * Leading edge software infrastructure;
- * World class IT network;
- * Multimedia Development Council (MDC) as a high powered, one-stop shop;
- * Top quality urban development in *Cyberjaya*, the intelligent city with multimedia industries, R&D centres, a multimedia university and operational headquarters of multinationals involved in the international multimedia trade.

In many of the MSC development activities, the Malaysian government that has an elaborate plan to leapfrog into the *Information Age* by providing intellectual and strategic leadership, is playing a major leading role. The Malaysian government believes firstly in investing in an environment that encourages innovation, secondly in helping countries, both Malaysian and international, to reach new technology frontiers, and thirdly in partnering with global IT players and providing opportunities for mutual enrichment and success. Among the areas identified for development are:

- | | |
|---------------------------|--|
| * Electronic Government | (Malaysian Administrative Modernisation Unit) |
| * Multipurpose Smart Card | (Banking sector) |
| * Smart Schools | (Ministry of Education) |
| * Telemedicine | (Ministry of Health) |
| * R & D | (Ministry of S & T and Environment) |
| * Manufacturing Web | (Ministry of International Trade and Industry) |
| * Borderless Marketing | (Multimedia Development Corporation). |

The Multimedia Development Corporation envisions a 20 year time frame for the full implementation and execution of the MSC and Malaysia hopes to achieve leadership in the Information Age by then.

The newly emerging economies such as China, Vietnam, Indonesia, Thailand are among the countries which are in the process of exploiting the situation with the help of other experienced economies, specially Singapore. Singapore had already extended its support to India to set up and manage software and information technology parks in many parts of the country, the most notable being the development of Bangalore dubbed the *silicon valley of India*.

It is claimed that the Information Technology park in Bangalore has been consciously designed and equipped with state of the art infrastructure not only to meet the specific needs of technology oriented companies, but also to address their particular concerns in infrastructural support, power supply and advanced communication facilities and is situated within the designated *Green Belt*. The park is meticulously landscaped and offers a refreshing environment conducive for working and living. Among the other successful Indian efforts are the Software Technology Park in Mysore, Centre for Development of Advanced Computing (C-DAC) in Pune, and the Software Technology Park in Hyderabad where the Competency Centre for Java (India) is located.

Development of such infrastructure is by no means simple. To put this in perspective, it is worth noting that the state run National Science and Technology Development Agency (NSTDA) of Thailand has invested Bhat 7 billion in creating Thailand's Science & Technology Park which is expected to give a major push to improve the country's science and technology development, both in the public and private sectors. It has integrated the neighboring Asian Institute of Technology (AIT) and Thammasat University to provide excellent graduate recruitment opportunities, collaborative research, tailored courses and training programmes. In order to make sure that there are sufficient researchers to staff the science park, NSTDA has granted 2000 scholarships to potential graduates.

IT National Initiatives in Sri Lanka

IT in Schools

By the end of the seventies, the microcomputer revolution has already reached the schools in developed countries. The developing countries too realised the potential of computers in the education system, yet were too busy arguing the economics of introducing computers into schools when the majority of schools lacked what was considered as basic facilities such as chalk and blackboards, laboratories, libraries and adequate numbers of properly trained teachers.

In 1983, the Computer Education Programme (CEP) of the Ministry of Education was initiated by the Minister of Education, with a view to introducing Information Technology at school level. A Computer Advisory Committee (CAC) was formed and was entrusted with the procurement of hardware, training of teachers and the preparation of syllabi and teaching material.

In the first phase of the CEP which started in 1984, 8 bit computers with 16-64 Kbytes of memory each were given to 108 selected schools. A total of two hundred and fifty teachers were trained initially by the Universities of Colombo, Moratuwa and Peradeniya, and DMS Ltd, a computer vendor. From the students' point of view the hardware resources at the time allowed only programming in BASIC and did not facilitate the use of popular application packages. Since not all thirty students in a class were interested in programming it was difficult to sustain the interest of the students as well as the teachers.

With the emergence of the Personal Computer (PC) in the early eighties came the second wave of development of the CEP project. The use of PCs allowed the diversification of the use of computers into non-science areas such as accountancy, management etc. The PC platform also allowed the use of common application software packages available in the market, without having to develop similar application software from scratch. However, both these phases of development were not successful mainly due to constraints imposed by the inability to provide the necessary hardware, software and human resources in sufficient numbers.

Computer Resource Centre Project

It had become clear that a radically different approach was needed to achieve the goal of exposing all students in all schools in the island to Information Technology. The Computer Advisory Committee therefore formulated a scheme to establish 300 Computer Resource Centres (CRCs) by equipping 300 schools with necessary hardware and software, and other infrastructure facilities. The Computer Education Department of the National Institute of Education (NIE) was given the task of co-ordinating the project and teacher training. With the limited resources available within the NIE, it also undertakes software development on a small scale.

The setting up of Computer Resource Centres had commenced in 1994 when 8 CRCs were setup by the Ministry of Education and Higher Education as a pilot project. The progress of these centres had been closely monitored and reported to the CAC. Based on the experience further 8 CRCs were setup in 1995 with local funds. In 1996, funds were obtained from the Asian Development Bank (ADB) to set up 30 more CRCs of which 16 were setup in 1997.

The success of this programme had led to the provision of local funds from the decentralised budget for the setting up of CRCs. Consequently, 13 centres have been set up bringing the total to 45. The balance 14 CRCs were completed in 1998 with the funds obtained from the ADB and a further 12 with local funding, bringing the total to 75.

The primary objective of this project is to expose the school leavers (after O/L and A/L examinations) to the latest IT applications in terms of hardware

facilities and application software features. Therefore, it was the consensus of the CAC that software should be based on the popular Windows platform and that students must be exposed to popular application packages that are used in industry. At each CRC, a Local Area Network (LAN) is available giving the opportunity to share hardware and software resources. The setting up of LANs has also served the purpose of an example to illustrate the use of LANs in the work place.

The training programmes run by the CRCs are designed to quickly expose the younger generation of the country to IT and thereby to make them computer literate. Each centre is expected to train 720 students per year and with a total of 300 centres, it is expected to provide training facilities for over 200,000 students annually. The private sector is expected to cater to an equal number thus bringing the total to about 500,000 per year. This is the total number of students in the O/L and A/L classes per annum.

In this training programme, students are given training on the application of computers for word processing, for the preparation of spreadsheets and the development of databases. These are primarily the areas of experience needed by industry. The training is at the applications level and with the experience, knowledge and skills acquired, the students will find themselves useful in offices, small businesses, etc.

However, as can be seen from Figure 1, there are a number of provinces which can benefit from increased number of CRCs. Therefore, careful selection of locations of these CRCs in the provinces is crucial for the success of this project.

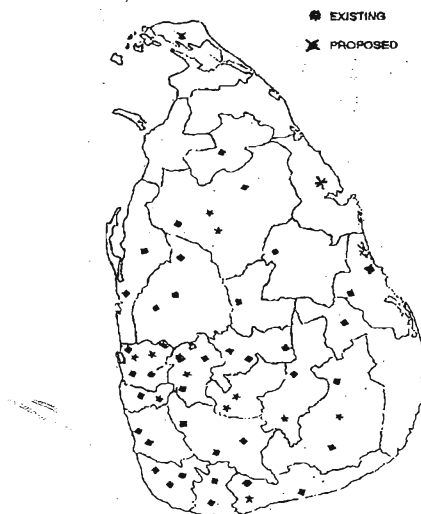

Figure 1: Computer resource centre programme of the NIE

Career Paths and Examinations in IT

The level of achievement of the students following the training programmes conducted by the CRCs is tested at the National Certificate in Computer Applications (NCCA), a public examination conducted by the Department of Examinations in Sri Lanka. NCCA provides three levels of certification namely, *basic*, *intermediate* and *advanced*. The number of applicants for this examination in the period 1995 to 1997 (Table 1) provides encouraging evidence of the growing popularity of this programme. Owing to the success, the private sector training institutes have already begun preparing students for this examination.

Table 1 : Number of applicants at the NCCA examination

Year	95	96	97
No. of applicants	4700	5400	14800

The computer training programme of the NIE is no doubt a very significant step in enhancing the computer literacy level of the younger generation of Sri Lanka. However, since these training programmes are pitched at the entry level, it is important to ensure a continuous path for career development for those who aspire to become specialists in IT. A number of avenues are available to achieve such professional status (Figure 2). Some examinations are conducted locally on behalf of the foreign examination bodies such as ACS (Australian Computer Society) and BCS (British Computer Society). The National Examination in Computer Studies (NECS), which has been promoted jointly by CSSL (Computer Society of Sri Lanka) and CINTEC (Council for INFORMATION TEChnology), represents a genuine local effort to establish a national examination of an acceptable and comparable professional standard to the foreign examinations. The foreign examinations however are more popular at the present moment with thousands of applicants sitting for them. It is very unfortunate that the number sitting for the NECS examination is in the order of 30–50 and has been steadily diminishing in the last couple of years.

NECS examination was conceived also to serve as a converging point to various training programmes offered by different training institutions, especially in view of the wide range of training opportunities available. The nomenclature used to classify these training programmes often tends to confuse the prospective trainees as well as employers and have led to difficulties in validating various certificate and diploma level training courses. Examinations such as NCCA and NECS, once stable, are expected to help in standardising these training programmes and assessment procedures.

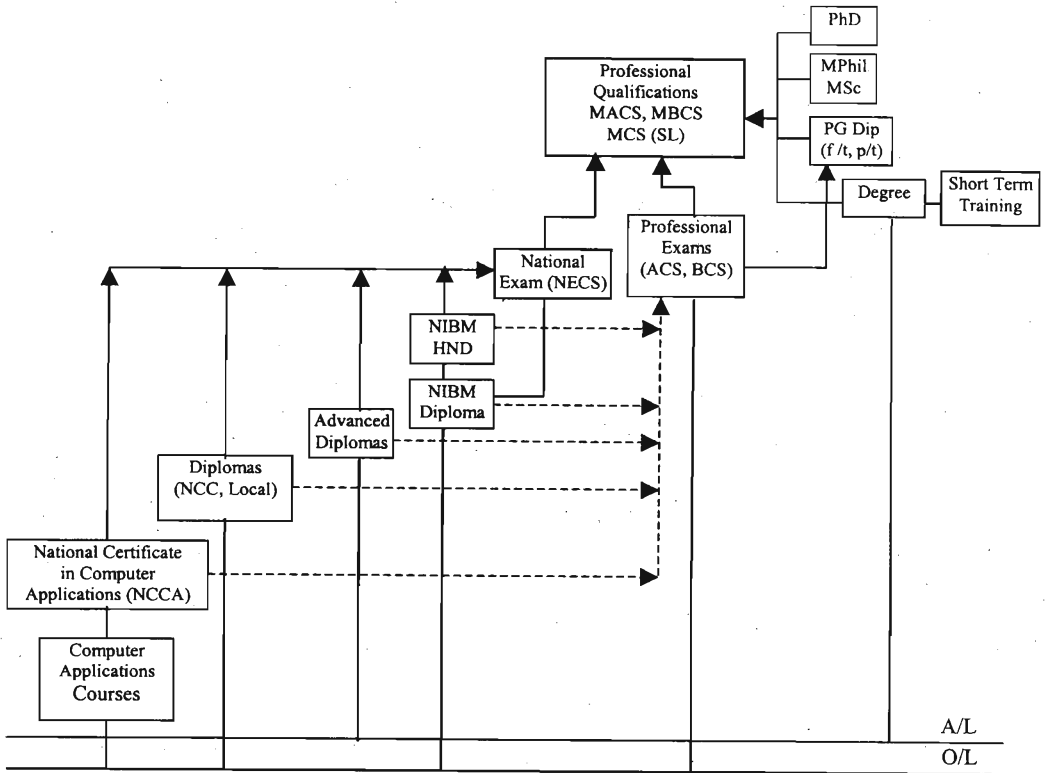

Figure 2: The matrix of training opportunities in Information Technology

IT in University Education

Early days

The formal use of computers in university education began in the early seventies when the Universities of Peradeniya and Moratuwa acquired IBM 1130 computing systems in 1971 and 1973 respectively. These were used mainly for the teaching of FORTRAN programming to students and also to carry out student projects and to support staff research. Later on, computing was integrated into the undergraduate teaching programmes. For instance at Moratuwa the computer was used by the engineering undergraduate students in preparing course work on power system load flow studies in Electrical Engineering, structural design in Civil Engineering, machine component design in Mechanical Engineering, etc.

The computing system at Moratuwa was also used for administrative purposes when in the late seventies, the university payroll and the University Provident Fund statements for the UGC were computed on this.

Prior to this, computer programming, mainly FORTRAN, was taught in some universities, primarily as a voluntary effort of individual staff members who were fortunate enough to have been exposed to computing during their postgraduate studies¹³. Although this was started as a pencil and paper exercise, some students were fortunate to have the opportunity of running their programmes free during off peak hours, on the ICL 1901 computer at the State Engineering Corporation or the IBM 360 computer at the Ceylon Census Department.

The integration of computing into degree studies, mainly in engineering and science, had been proposed to the UGC on many occasions prior to 1980. The University of Colombo had even succeeded in incorporating Statistics, with an element of Computing, to the Mathematics degree. However it was in 1983, when the government took serious notice of the relevance of computing in all faculties of studies, based on recommendations¹⁴ made by Prof Colin Reeves who was commissioned by the ODA/BC (Overseas Development Administration of the British Council). Reeves' Report, or the Blue Book as it was fondly called, recommended a multi-pronged strategy for the inclusion of computing into degree programmes in Sri Lanka. The report placed special emphasis on the need to provide suitable hardware, software and courseware, and also the need to undertake manpower development so that computing can be effectively taught to students not only in science streams but to those students in social sciences, humanities, management, etc.

As a result of the acceptance of Reeves' recommendations, the Ruhuna-Keele link was established with the object of firmly rooting computing in the university study programmes. Teacher training workshops and course material development sessions were held with the participation of foreign and local university staff. The course materials thus produced were made available to the students at cost. University staff were given postgraduate or advanced training in the UK mainly at the University of Keele and Staffordshire Polytechnic (now Staffordshire University). Although some of the staff who were trained under this link programme have now left the universities and the initial hardware and software provided have become obsolete, the initial impetus given to all disciplines to incorporate computing is of great significance.

It was around the same time that two other important directions were taking shape. On the one hand NARESA (Natural Resources Energy and Science Authority of Sri Lanka), the predecessor of NSF (National Science Foundation of Sri Lanka) was directed by H E the President to formulate a national computer policy (COMPOL). At the same time some of the universities were already drawing up Computer Policy guidelines to complement the national effort. As a result a complete policy framework became available by the end of 1984 which outlined the policy structure for IT development in Sri Lanka as well as specific policy guidelines for the development of teaching of computer science in universities. While the individual

policy directions dealt with the vertical development of computer science as a discipline, Reeves' recommendations primarily dealt with the lateral development by proposing to introduce computing to other disciplines taught in Sri Lankan universities. It was felt that both these approaches were necessary for the successful integration of computing into the higher education system in Sri Lanka.

Undergraduate Studies in IT

All the policy statements had identified human resources development in IT as a key element and placed emphasis on the need to reach a "critical mass" to sustain any efforts in IT development in the country. The University of Moratuwa Computer Policy further identified networking and distributed computing as the guiding principle in the development of teaching of computer science in the university¹⁵. The acceptance of Reeves' recommendations by the UGC and its implementation gave a tremendous boost to computing as well as teaching computing in Sri Lankan universities¹⁶. Supported by these and also by the policy guidelines formulated by the individual universities, teaching departments of Computer Science/Engineering were established in the Universities of Colombo, Moratuwa and Peradeniya in January 1985¹⁷. Today these three departments produce graduates in Computer Science (BSc or BSc Special), Computer Science & Engineering (BSc Eng) (Figure 3) and Electrical Engineering with Computer Science (BSc Eng) respectively. In addition the Open University produces graduates in Computer Technology at the BTech level. Most of the faculties in the other universities have successfully incorporated computing into their study programmes making graduates from these departments to be computer literate. Almost all the undergraduates entering the universities today are given an introduction to computing, irrespective of their area of specialisation.

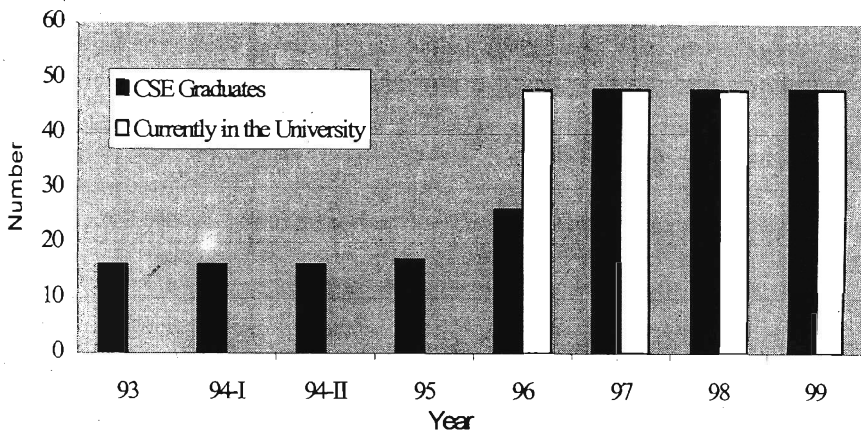

Figure 3: Numbers of students in computer science and engineering at the University of Moratuwa

University of Peradeniya first and the University of Moratuwa next were fortunate to receive assistance under the Japanese Grant Aid scheme. Both universities enhanced the computing facilities by setting up modern computing laboratories. The timing was right in 1989 for the Department of Computer Science & Engineering of the University of Moratuwa to establish a computing facility based on world wide industry standards such as Ethernet for Local Area Networks (LANs) and TCP/IP (Transmission Control Protocol/ Internet Protocol) for communications, the UNIX operating system and PCs as workstations. ✓

The first batch of 16 students to follow a computing degree course in a Sri Lankan university was admitted to the Department of Computer Science & Engineering in 1986¹⁸. Their graduation was delayed until 1993 due to the general unrest which prevailed in the country in the period 1988-1990. The annual intake is now increased to 48. However it is still less by a factor of at least two, compared to what the country actually needs but restrictions in the university infrastructure have prevented the Department from increasing the intake any further. The Department of Statistics & Computer Science of the University of Colombo admits 30 students for the BSc special degree since 1990. The total output of computer science graduates from all three universities is still less than 200 a year, which is totally inadequate to sustain a volatile industry such as the *Information Industry* where overseas employment opportunities and staff turnaround are both very high.

In recognising the shortfall in the state education system in producing enough computing manpower, many training programmes were initiated by private sector organisations. Two particular initiatives of interest to this discussion are the Computer Science degree programmes conducted by the Institute of Technological Studies (ITS) in collaboration with the University of Houston, Clear Lake, USA, and the Informatics Institute of Computer Studies (IICS) in collaboration with the Manchester Metropolitan University, UK. The intake to these two study programmes is 50 and 100 respectively. Although a large number of private institutes in Sri Lanka are involved in providing IT training at other levels (non-degree), the number of training places provided by them is not available.

In comparison, India has 150 universities and 460 institutes offering computer education at degree level and produces 115,000 computer science/engineering graduates per year. In addition there are 1600 private training institutes involved in providing computer training. As a result more than 155,000 computer professionals are available to join the IT industry every year¹⁹.

Postgraduate Studies in IT

At the present moment, almost all taught postgraduate study programmes in Computer Science are conducted by the Department of Statistics & Computer Science (DSCS) and the Institute of Computer Technology (ICT) of the University of Colombo.

The MSc programme at Colombo was established with UNDP assistance in 1990 and the PG Diploma programme of the ICT was funded by the Japanese Government through JICA in 1989. The intake to the PG Diploma of the ICT is shown in Figure 4.

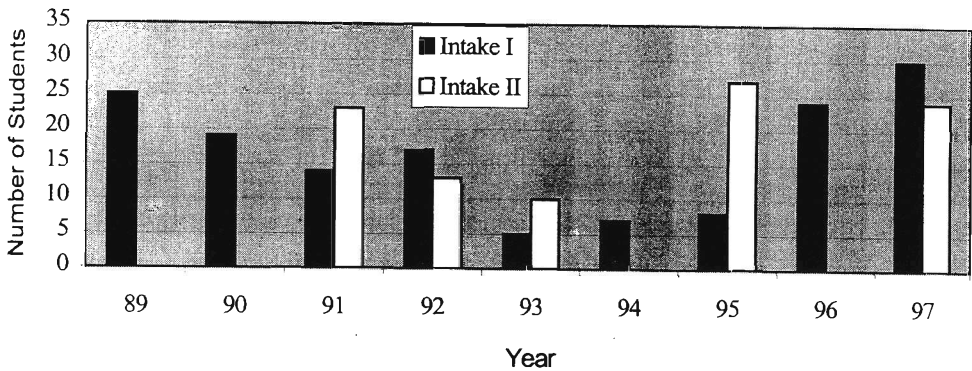

Figure 4: Student intake to PG Diploma of the ICT, University of Colombo

A total of 218 students have been admitted to the MSc course in Computer Science at the University of Colombo from the inception. Of this 120 students are following the course at the present moment.

Postgraduate study by research at MPhil/PhD level has been undertaken by several universities, but in an ad-hoc manner.

A more recent initiative is the MSc programme run by the Department of Electronics and Telecommunication Engineering of the University of Moratuwa, for 18 students. Although not directly in Computer Science or Computer Engineering, the above study programme in Electronics and Telecommunications, which has a reasonable content of IT, is very relevant to the IT industry in the country specially in view of the global convergence of Computer and Communication technologies. Recognising the importance and need for the enhancement of postgraduate teaching in Sri Lanka, a loan has been provided by the Asian Development Bank (ADB) for the enhancement of postgraduate teaching in the universities. Having recognised the present day worldwide demand for expertise in data communications, computer networking and software engineering, the Department of Computer Science & Engineering of the University of Moratuwa is already making preparations for the conduct of MSc courses in Distributed Computing Systems and Software Engineering utilising the funds provided by ADB.

IT in other study programmes

Reeves' recommendations in 1983 formed the basis of introducing IT into all teaching programmes in the university education system in Sri Lanka. Computer units were set up in each university to serve the needs of these departments of study. The application of IT and its benefits became more apparent in some areas such as geography, town planning, archaeology, pharmacology, etc than others, where spatial mapping data in digital format tremendously enhanced the users' ability to manipulate and interpret them. Most of the departments have now established their own computing facilities with software relevant to support their specific teaching and research application needs.

IT as a vehicle for Teaching and Learning

With the proliferation of LEARN²⁰ (now known as Lanka Educational And Research Network), and hence access to the Internet, more and more exciting opportunities for teaching and learning at higher education level have emerged. Academics and university students today have access to data repositories of the world, held in libraries, museums, universities, etc. in other countries in true multimedia format. If not for the restricted bandwidth of the line connecting LEARN to the global Internet, these resources could have been freely used by Sri Lankan staff in their teaching and research, and students in their learning and research activities.

Advanced computer networking infrastructure coupled with sophisticated information services is becoming a major driving force in providing opportunities for distance learning and continuing education in developed countries. Many teaching packages, specially adapted to the electronic medium through which they are presented to the student, are now delivered to the students through the networked PC. The student will then study the material at his/her own pace and will appear for assessment when he or she is ready. This mode of learning has made *life long learning* a truly exciting experience, although educators are still debating about the benefits of traditional class room face to face teaching and learning.

In the UK, the "National Grid for Learning" (NGL) has been proposed to provide a national focus and agenda for harnessing new technologies to raise educational standards, quality of life and Britain's international competitiveness, and especially to achieve the new literacy and numeracy targets. The implementation of NGL is expected to rely heavily on C&IT (Communications and IT), a concept strongly supported by a recent commission report on Higher and Further Education in the UK³. In Sri Lanka, the Open University should exploit the features and facilities offered by C&IT for distance learning and teaching and incorporate C&IT to enhance the scope of their teaching programmes.



The availability of such resources to the teachers and students in secondary and even in primary schools is equally important although the economic conditions of developing countries including Sri Lanka do not readily permit such provision. Once LEARN acquires adequate international line band width it may then be possible to provide connectivity to the Computer Resource Centres thereby giving an opportunity to those students following the CRC training programmes to access the educational resources on the Internet.

The Internet and Sri Lanka

LEARN initiative

The first attempt at internetworking in Sri Lanka dates back to 1989, when the author proposed to the Government of Sri Lanka the setting up of LEARN - Lanka Experimental Academic and Research Network²¹. This proposal was made much before the Internet, based on the Internet Protocol (IP), gained commercial popularity in the world circa 1992. Consequently Version 1.0 of the LEARN proposal was based on the ISO X.25 family of packet switching protocols^{22,23}. Fortunately or unfortunately, the X.25 based solution was never implemented and with the early realisation that the Internet Protocol is going to conquer the internetworking world, a revised version of LEARN based on IP was proposed in 1992 and was implemented^{24,25,26}. LEARN hence became the forerunner of IP networking in Sri Lanka and has served as a test bed for many different technologies and services. It is also worth noting that LEARN, which now provides connectivity to most universities, has been established entirely with local funds and local expertise.

The principal objective of LEARN is to provide national interconnectivity between all the academic and research institutions in Sri Lanka and also to provide international connectivity to foster international collaboration between Sri Lankan academics and researchers and their international peers. As a first step towards this, *LEARNmail* electronic mail (e-mail) service was started in June, 1990 with the assistance of University of Moratuwa, the University Grants Commission (UGC), and the Computer & Information Technology Council (CINTEC)²⁷. The remote end of the link was managed voluntarily by a number of Sri Lankan students who were doing their postgraduate studies in the US at the time.

However, the history of e-mail in Sri Lanka goes back to 1988 when the Arthur C. Clarke Centre for Modern Technologies (ACCMT, now ACCIMT) attempted to set up an email network using Mallard Mailboxes based on a proprietary protocol. After a few months, the excitement died down perhaps because of the proprietary nature of the protocol used in the Mallard Mail boxes which required cumbersome gatewaying to communicate outside the "Mallard user club".

In the meantime, the Sri Lankan students in the US and UK with the support extended by well-wishers made a joint effort to set up SLNet. SLNet is a moderated mailing list with a sophisticated mail relay system deployed in many countries for automated email delivery service to its registered subscribers²⁸. The SLNet service was used by thousands of Sri Lankans abroad to receive news fed by many volunteers around the globe who picked up news from international editions of newspapers, radio and Reuters.

The success of SLNet and the continued support from the well-wishers led to the formation of LAcNet²⁹, a not for profit organisation registered in USA, with the objective of promoting the development of Information Technology in Sri Lanka. In keeping with this objective, LAcNet provided financial assistance from January 1991 until December 1994, to operate the *LEARNmail* service, for the benefit of many hundreds of educators and scientists in the country who regularly use *LEARNmail*.

Since 1993 LEARN has been connected to the Internet, first through IDD and later using the Datapac X.25 packet switching service of Sri Lanka Telecom. From 1993 to 1995, only restricted Internet services were offered to LEARN users due to the extremely high operating costs of the IDD first and the Datapac services later. Finally LEARN was connected on line to the Internet through a leased line obtained from Sri Lanka Telecom with funds provided by CINTEC. Since then full Internet Service has been provided to all LEARN users.

Today LEARN connects 8 universities and the National Science Foundation (NSF)³⁰ on-line using leased lines operating at 64 Kbps (Figure 5). Sabaragamuwa, Rajarata and South Eastern Universities are still not connected on-line and are given dial up access. Jaffna University is yet to be connected to LEARN. In addition the Arthur C Clarke Institute for Modern Technologies (ACCIMT) is connected on-line using a 64 Kbps link through the University of Moratuwa node. The National Engineering Research and Development (NERD) Centre and the Industrial Technology Institute (ITI) are expected to receive on-line connectivity shortly.

Forty other sites, mainly universities and research centres, are provided with UUCP (UNIX-UNIX Copy Program) accounts for email and a further twenty sites are given POP (Post Office Protocol) accounts for email. In addition about 30 dial up access accounts and 50 POP mail accounts are provided to the staff members of universities and research institutes. The use of UUCP and POP mail accounts by the larger institutions represents an inexpensive solution for the provision of an email service especially when dedicated access links are not available. A single local or national long distant telephone call allows an organization to upload the outgoing mail and download the incoming mail belonging to more than one user. Of course the duration and hence the cost of this call depends on the volume of email for that organisation.

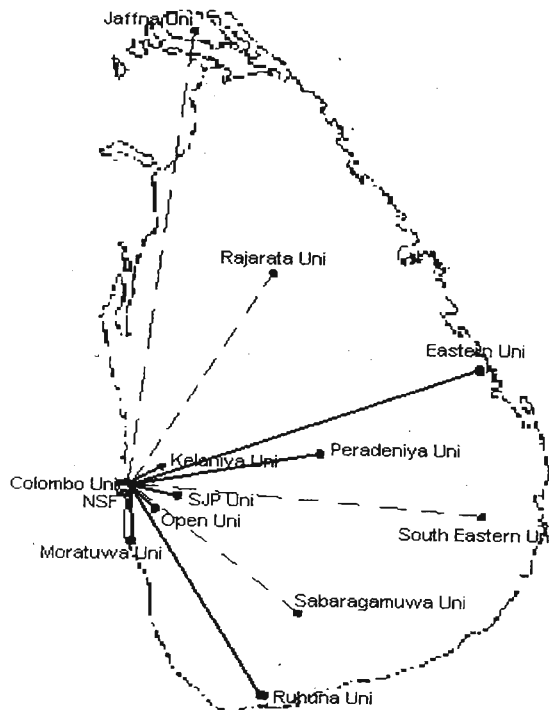

Figure 5: LEARN connectivity (November 1999)

Figure 6 shows the growth of *LEARNmail* users from the inception of LEARN in 1990. Although the number of users has increased five fold (500 to 2500) in less than 3 years, the bandwidth of national links still remains at or around 64 Kbps with only the international link upgraded to 192 Kbps recently. The local line bandwidth is a serious bottleneck specially in view of the increasing web traffic. This is causing extreme congestion making LEARN almost unusable during peak times of the day.

The traffic carried by LEARN on a typical day and the usage by institution are shown in figure 7. Figure 8 shows the weekly traffic pattern on the international link connecting LEARN to the Internet for the week ending on November 19, 1999. It is evident from the traffic graph that this link with a nominal capacity of 192 Kbps (24 Kbytes per second) is used heavily during most part of the week days with much lower activity on Saturday and Sunday. The international traffic carried by LEARN is about 18 gigabytes (1 giga = 10^9) per month on average. It is not uncommon for World Wide Web access to be responsible for generating a large portion of this traffic.

In comparison SuperJANET³¹, the academic and research network in the UK, had carried 28 terabytes (1 tera = 10^{12}) in October 1999, a figure which doubles every 6 months. Of this about 60-70% accounts for WWW traffic.

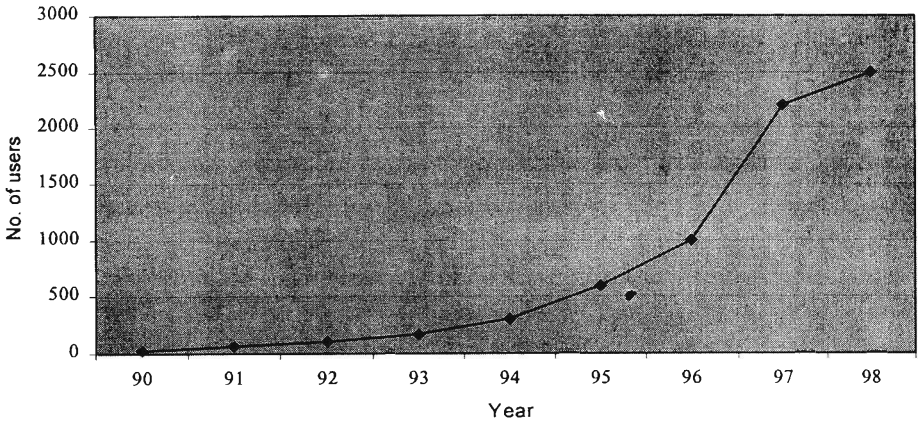

Figure 6: Growth of *LEARNmail* users

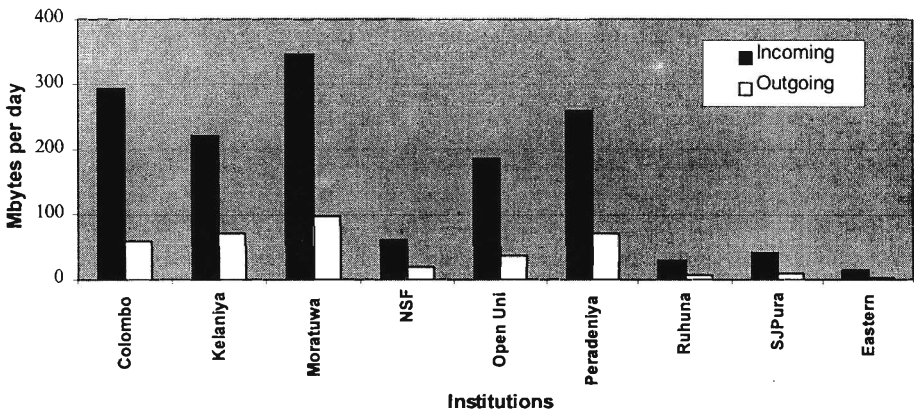

Figure 7: Typical daily usage of LEARN (mid week November)

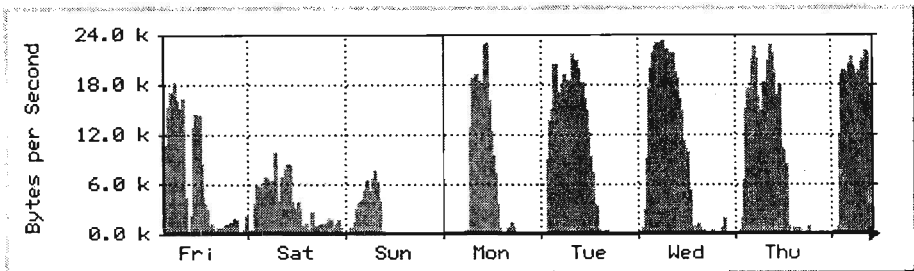

Figure 8: Weekly traffic pattern on the international link to the Internet (November 1999)

Internet Service Providers (ISPs) in Sri Lanka

Internet was introduced to Sri Lanka in 1992 when LEARN used IDD first and the Datapac service of Sri Lanka Telecom later, to provide connectivity to the academic and research community in the country³². LEARN is the first ISP in the country and also the network service that began to provide Point of Presence (PoP) outside Colombo. LEARN now provides either full or in some cases dial up Internet services to students and staff of almost all universities (Jaffna is the only one not connected yet). Some universities also allow dial up access to their staff members giving Internet access for the cost of a local telephone call. Of the research centres only the NSF and the ACCIMT are connected on line. NSF serves as a focal point for the dissemination of scientific and research information available through the Internet to the scientific and research community in the country who do not have direct access to the Internet. Various delivery mechanisms including the more modern email or fax and the traditional postal mail services are used by NSF to deliver this information to the end user.

The first commercial ISP in Sri Lanka had commenced its operation in 1995 and as of this writing there are 8 registered commercial ISPs in Sri Lanka. The growth of Internet usage in Sri Lanka (Table 2)³³ when compared to the global growth of the Internet (Figures 9 & 10) however is not very impressive. Three reasons can be attributed to the slow growth of the Internet in Sri Lanka compared to the explosive growth of the Internet worldwide³⁴:

Table 2: Growth of Internet subscribers in Sri Lanka

Name of ISP	Operation commenced in	Number of Internet Subscribers					
		95	96	97	98 ^a	99 ^a	00 ^a
Lanka Internet	1995	860	2519	3920	5725	8600	12000
CeyCom Ltd	1996	-	200	1370	2770	4570	6570
DataNet Ltd ^b	1996	-	10	60	270	370	640
Electrotek Ltd ^b	1996	-	250	260	270	300	325
Sri Lanka Telecom	1996	-	1200	2000	3700	5000	6000
Eureka Online Ltd	1997	-	-	1515	3550	5650	8300
ITMIN Ltd	1997	-	-	604	1206	3215	9000
Pan Lanka Net Ltd	1997	-	-	400	1200	2600	4000
TOTAL		860	4199	10129	18691	30305	46835

^a estimates^b targets corporate customers only

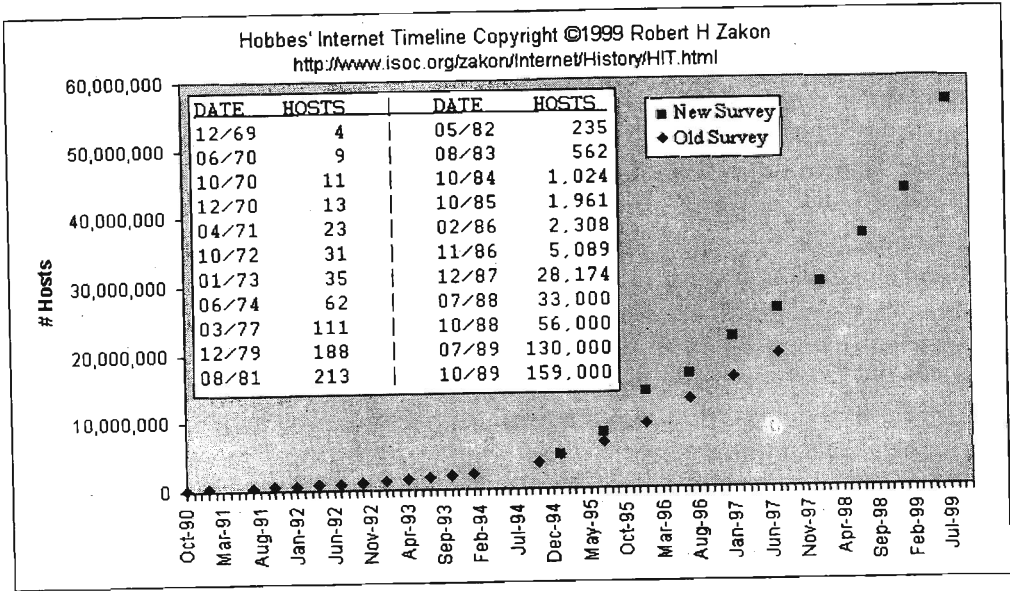

Figure 9 : Growth of the number of hosts on the Internet

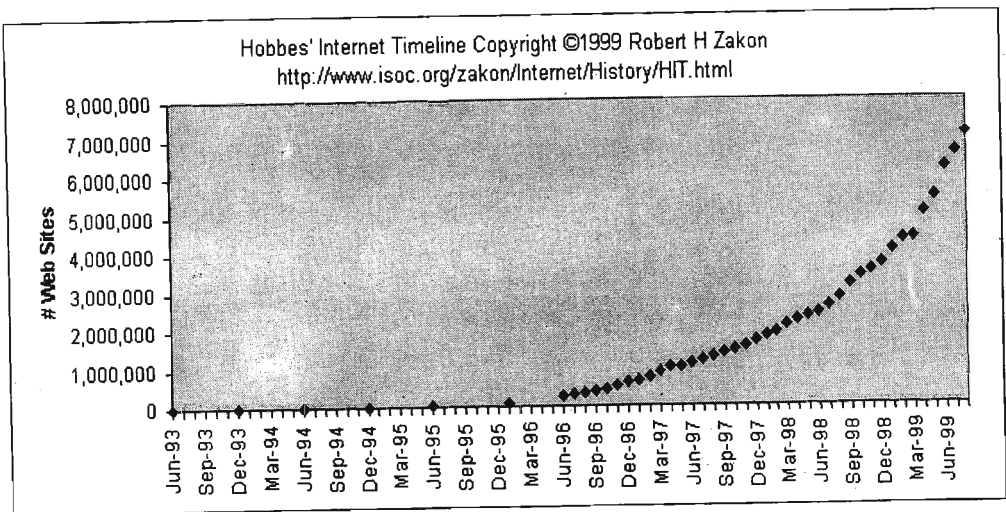

Figure 10 : Growth of world wide web servers on the Internet

- i. Telephone connectivity is still mainly confined to the Colombo Metropolitan area and hence people outside Colombo will not be able to have access to the Internet at the cost of a local phone call.
- ii. The restricted access to telephones outside Colombo had discouraged the commercial ISPs to set up PoPs outside Colombo thereby slowing down the growth.
- iii. Home PCs are still not a popular commodity in Sri Lanka. The government policy with regard to the import duty of computers had not been clear although there is no duty at the present moment. The problems associated with unstable electricity supply and the belief that high humidity and high temperature can seriously damage computers are contributory factors too.

From the above it is clear that the commercial ISPs target to achieve a total of 50,000 Internet subscribers in Sri Lanka by the turn of the century. Although this is a very small number compared to the millions of Internet users worldwide (see Table 3), it still remains to be seen whether even this can be achieved given the present rate of growth of the telecommunication sector in Sri Lanka.

Table 3: Internet users (September 99)

The World	199 million
North America	109 million
Europe	45 million
Asia/Pacific	38 million
Latin America	5.6 million
Africa	1.2 million
Middle East	0.92 million

Figures 9 & 10 show the explosive growth of the global Internet and one of its very pervasive services, the World Wide Web (WWW) respectively^{35,36}. The number of computers (hosts) connected to the Internet is expected to reach 100 million in the next century and it is a conservative estimate that there will be 500 million users on the Internet by then.

(Table 4 shows the number of computers connected to the Internet in a few selected countries of the world as of July 1999.)

Table 4: Number of computers connected to the Internet (July 1999)

Top Level Domain	Domain Name	Hosts
Japan	jp	2,072,529
United States	us	1,555,882
Singapore	sg	103,862
China	cn	62,935
Malaysia	my	53,447
Thailand	th	27,690
India	in	17,979
Pakistan	pk	3,027
Sri Lanka	lk	983
Maldives	mv	217
Nepal	np	160
Cambodia	kh	144
Bhutan	bt	68
Vietnam	vn	34
Myanmar	mm	1
Bangladesh	bd	1
Afghanistan	af	1

Growth of Telecommunications Sector in Sri Lanka

The telecommunications sector development is a key parameter in attempting to achieve socio-economic growth in a country through the deployment of high tech industries. Teledensity, defined as the number of telephones per 100 inhabitants, is often used as an indicator of the level of economic development in a country. Figure 11 shows the growth of telephone connectivity in Sri Lanka in the 90s. Accordingly the teledensity had barely improved, rising from 0.78 in 1992 to 1.7 in 1997 (Table 5)³³. Teledensity is expected to reach 4.68 by the turn of the century. In comparison with developed countries as well as newly industrialised countries, this is still a very low figure³⁴.

Table 5: Teledensity in Sri Lanka

Year	92	93	94	95	96	97	98	99	00
Teledensity	0.78	0.9	1.0	1.12	1.39	1.70	3.03	3.83	4.68

Coupled with the low teledensity is also the problem of distribution of tele connectivity in the country (Table 6). At the present time, more than 68% of telephones are in the Colombo metropolitan area and this is not going to change very much in the next few years. In other words the proliferation of telephone based services such as telebanking and Internet access will be restricted due to the non availability of telephone connectivity outside the capital city. This will also slow down the growth of business and trade centres outside the Colombo metropolitan area.

Table 6: Distribution of tele-connectivity in Sri Lanka

City/Town	Colombo	Kandy	Galle	Matara	Other
% telephones	68	4	2	4	22

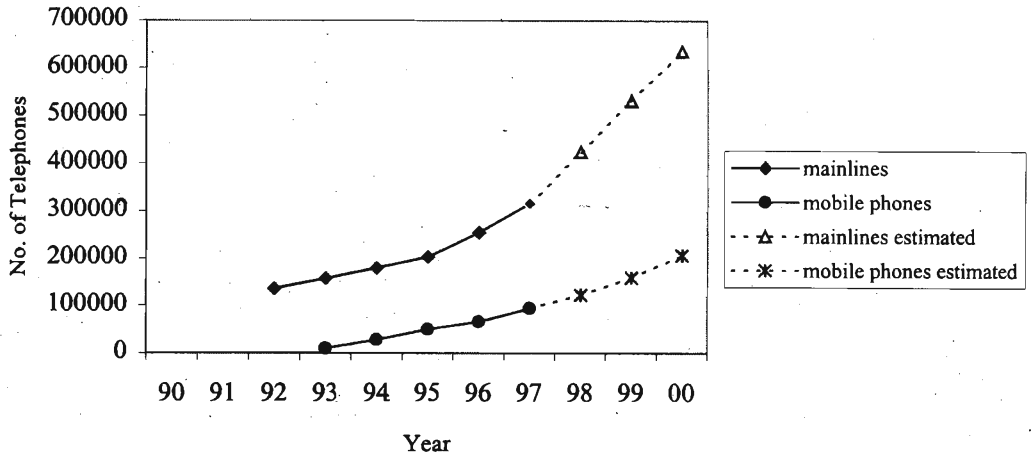

Figure 11: Telephone connectivity in Sri Lanka

An aggressive policy for the development of Telecommunications Sector in Sri Lanka is therefore needed to support the anticipated growth of the Information Technology sector and its successful integration into the socio-economic development process of Sri Lanka^{37,38}. This is also a prerequisite if Sri Lanka is to be successful in inviting foreign investors to contribute to the development of the technology and industry bases in Sri Lanka. Schemes like Science Parks, Software Industry and Information Technology Parks can only succeed if the required infrastructure to support such rapid development is already in place. This is especially critical in view of the strong competition from already established Software and Information Technology parks in the region, for instance in Bangalore (Silicon Valley of India) and Kuala Lumpur (Multimedia Super Corridor of Malaysia), to name just a few.

The traditional telecommunication operators and their services are already threatened by the proliferation of Internet based services. Already *email* had taken the place of postal mail and facsimile services, and *Internet Phone* service has started to provide a viable alternative to the traditional voice telephony which has been a monopoly of the telecommunication operators. These will essentially change the way in which telecommunication business is conducted, and hence the telecommunication operators have to take serious note of these developments and the consequences on their own operations.

Until recently, Sri Lanka Telecom had a monopoly in providing dedicated circuits for data communications. Although deregulation has brought other operators into the field, it had still not solved completely the problem of how to provide a dedicated data circuit of the required capacity at an affordable cost within a reasonable time. Sri Lanka Telecom had been slow in realising the importance of data communications and hence in taking steps to provide necessary line bandwidths, despite the fact that until recently, it was the only carrier which had the required coverage and the technical ability. Even today, 64 Kbps is the commonly available line bandwidth and 2Mbps promised in the future.

It has been difficult for traditional voice communication service providers such as Sri Lanka Telecom, to realise that data communication links need higher capacities and hence extra capacity must be built into their systems. In their view a 64 Kbps circuit for data meant a lot of bandwidth, but little did they realise that, in terms of voice telephony, this is the equivalent of one voice channel!! What has been used so far for connecting LEARN sites together are links with equivalent capacities of one voice channel each! In the same way a 2 Mbps data circuit would translate into 30 voice channels and a 45 Mbps data circuit would mean about 700 voice channels. However pulling out a few 2 Mbps circuits for carrying data from the already congested voice network in Sri Lanka would be disastrous!

On the above basis, if Sri Lanka were to intensify the application of IT for economic development, the present state of data communication and voice communication infrastructure is certain to become a major bottleneck. This has been partially tackled by private sector initiatives by installing high speed data links to selected areas in the island. However Sri Lanka should seriously consider the establishment of a country wide backbone connecting the major trade and industrial cities together (Figure 12) using a Broadband ISDN (BISDN) technology such as ATM (Asynchronous Transfer Mode). The network shown in Figure 12 must be expanded to the other areas of the country as the demand grows.

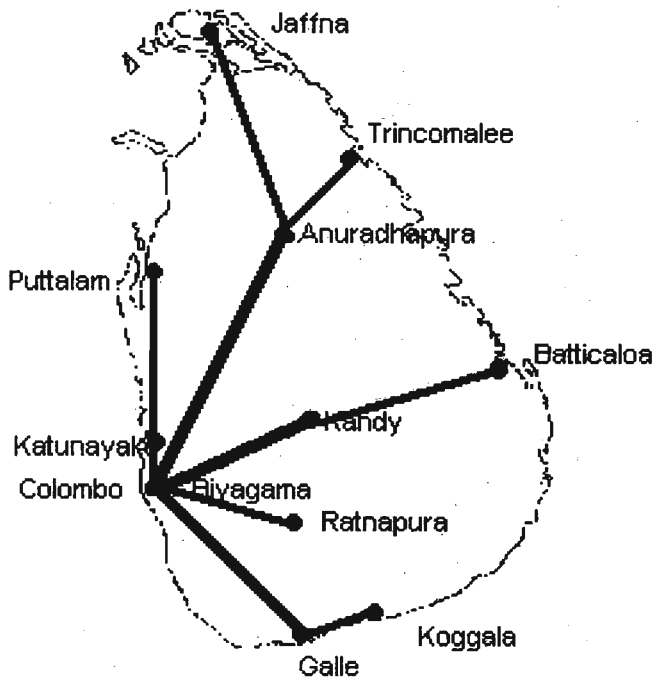

Figure 12 : A backbone data communication network for Sri Lanka

The demand for bandwidth by various telematic applications as time progresses is shown in Figure 13. As can be seen, the world is on the threshold of crossing the 500 Mbps level for real time applications such as video on demand. This type of bandwidth will be made available using BISDN technologies such as ATM. In comparison, Sri Lanka is still at the level of usage of 1985, when 64 Kbps was the norm worldwide.

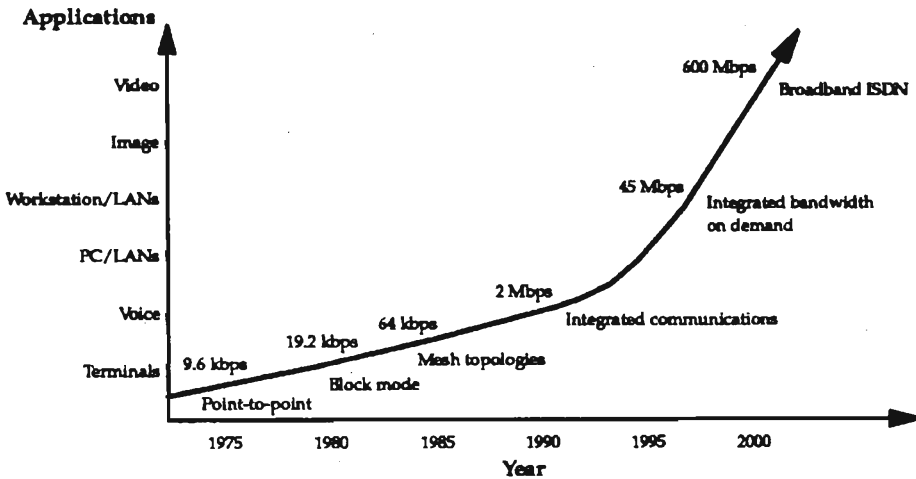

Figure 13: Variation of bandwidth utilisation

Research Information Infrastructure (RII) in Sri Lanka

Many countries in the world are in the process of defining elaborate National Information Infrastructure (NII) initiatives with a view to integrating into the Global Information Infrastructure (GII) and deriving economic benefits from the same. Developed countries have also invested heavily in establishing Research Information Infrastructures (RIIs) for the sustained growth of technology and industry. Most of the developing countries including Sri Lanka have failed to recognise the role of such RIIs for the rapid development of the country's economy. Of course the reluctance to set aside money to establish an advanced RII is not without reasons, especially when there are seemingly more urgent areas that require immediate investment. However what is not often understood is the contribution the scientists and researchers can make to the overall socio-economic development of a country through scientific and technological breakthroughs, if they are given better and enhanced access to world wide information resources. This is a fact that had been well understood by the developed world but often overlooked by developing economies³⁹. This is made clear by the commitment of countries such as USA, UK, Japan and Malaysia to the development of super information infrastructure. The latest of such moves include the Internet2 (USA), SuperJANet4 (UK) and the Multimedia Super Corridor (MSC - Malaysia). Japan along with many participating countries in the Asia Pacific region is engaged in creating APAN - Asia Pacific Advanced Network to promote regional information cross flow.

The Internet2 and SuperJANet4 are multimillion dollar projects aimed at providing high speed network connectivity to support applications such as:

- * Distance learning and support of remote students
- * Delivery of on line resource based learning, including real time audio and video material
- * National and international collaboration, especially in research
- * Remote access to information and expertise
- * Remote access to scarce and expensive resources

The growth of distance learners, through the process of life-long learning, is creating new student needs which must be satisfied. High speed computer networks with easy and economical access to the resources on them, have made this possible in developed countries.

SuperJANet4⁴¹ based on the Asynchronous Transfer Mode (ATM) technology is designed to provide a core network operating at 622 Mbps using optical fibre technology, with access links operating at 155/34 Mbps. The emphasis is on connecting the MANs and SuperMANs (collection of MANs in a region) together with the ATM backbone. International connectivity to SuperJANet is provided by 3 links each rated at 155 Mbps. Two of these links connect SuperJANet to the US Internet and the third to the Trans European research network, TEN-155⁴⁰. SuperJANET now provides connectivity to all universities and most higher education colleges (174), research centres (33) and colleges of further education (90) in the UK. Within the next 2 years all colleges of further education, numbering about 400, will have connectivity as well⁴¹.

SuperJANet3, the current incarnation of SuperJANet, has been designed with a vision to develop into a gigabit network, which is what the UK academic and research community will need in the next millennium. The innovative nature of the SuperJANet3 project has been recognised by the British Computer Society in their 1994 Awards, and by the Smithsonian Institute, Washington DC when SuperJANET was selected as a finalist in the 1996 awards.

The information services made available on SuperJANet3 are very extensive⁴². In addition to enhanced email distribution services such as Mailbase, there is a range of value added services in a number of specialist areas. Several Electronic Data Set Services are provided in the areas of arts and humanities (AHDS), bibliographic (BIDS), bibliographic and digital map data (EDINA & MIDAS), census, macro economic time series data banks, etc. to name a few. The high speed backbone also supports a fully featured Video Conferencing Service (VCS) used on a regular basis for tele-teaching as well as for tele-meetings.

Internet2 is a project of the University Corporation for Advanced Internet Development (UCAID) in the USA. The objectives of Internet2, which is a collaboration of more than 150 US universities working with industrial partners, are very similar to SuperJANet4. Internet2 aims to establish gigaPoPs (gigabits per second Points of Presence), through which US universities will have access to very high performance Backbone Network Service (vBNS) of the US National Science Foundation. It will also provide access to other important networks such as NASA Research and Education Network (NREN) and any future networks of the Next Generation Internet (NGI). The Next Generation Internet is an initiative to achieve network speeds 1000 times faster than today's networks.

In Sri Lanka, the National Science Foundation (NSF - formerly NARESA) in its role as the focal point for the dissemination of scientific and technological information, has taken steps to establish a primary RII for the benefit of the scientific community in the country⁴³. During the past 25 years NARESA (now NSF) has developed basic S & T Information Infrastructure by collecting, storing, processing and disseminating information and also by facilitating the introduction of new and effective technologies and information services for the benefit of scientists in Sri Lanka. More recently with the financial assistance from SIDA (Swedish International Development Agency), a network of multimedia-capable workstations is already connected to the Internet through LEARN providing access to the in-house data bases as well as international databases on CD-ROMs. The use made by the scientific community in Sri Lanka of these services is reflected to some extent by the traffic from NSF carried by LEARN (Figure 7).

In taking this initiative a step further, NSF in collaboration with LEARN, has initiated the development of a high speed local network on Vidya Mawatha (Figure 14) to provide high speed, high bandwidth connectivity to all scientific, professional and research organisations situated along this road. The completion of this project is expected to bring our scientists, researchers and other professionals closer to the global community. Moreover this is also expected to serve as a pilot for many other similar development schemes in the country, the most notable one being a high speed metropolitan area network (MAN) for Kandy area connecting the University of Peradeniya to the scientific and research centres in and around Kandy. Once the Vidya Mawatha LAN is setup the backbone connectivity with the rest of the scientific community will be through LEARN and the global Internet⁴⁴.

NSF (formerly NARESA) has, over the years, promoted human/organisational networks and specialist subject oriented networks with a view to making more effective sharing of information and facilitating meaningful interaction of scientific personnel with similar interests. NARESA had given the initial impetus for the development of computerised data bases to facilitate the exchange of S & T information at national level. These efforts of NARESA had been complemented by the activities of organisations such as Sri Lanka Standards Institution (SLSI) which

provides bibliographic information on standardisation and related areas, Industrial Development Board (IDB) which operates the information services to the industrial sector, Agrarian Training and Research Institute (ARTI) which serves the agriculture related community, Export Development Board (EDB) which serves the export sector, and more recently ITMIN⁴⁵ and TRADENET which provide trade, industry and market information.

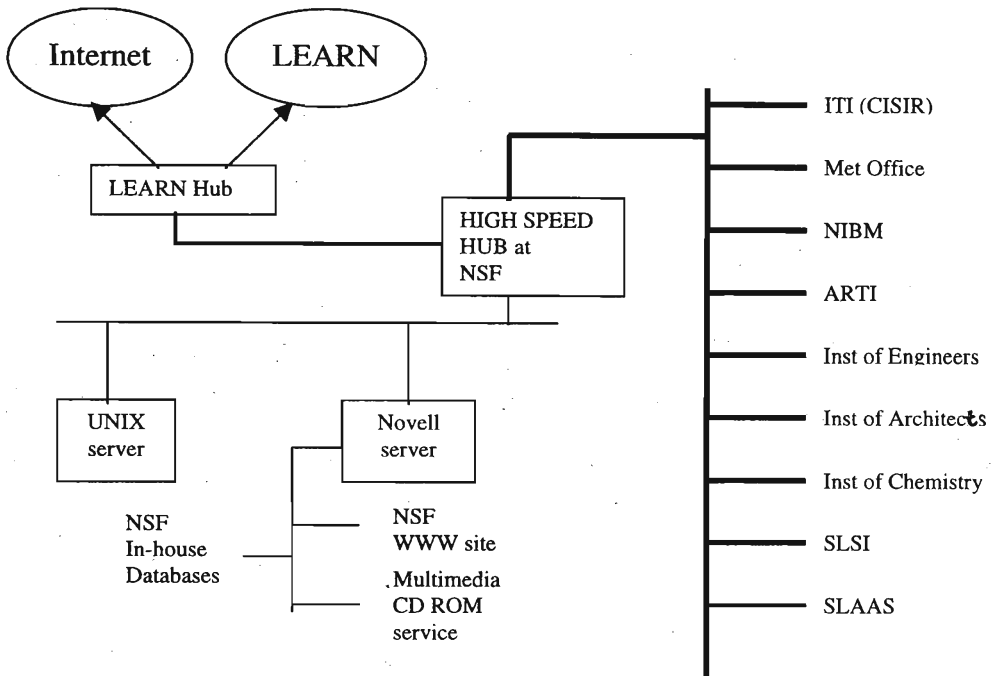

Figure 14: Vidya mawatha high speed network (proposed)

Growth of Internet Based Services in Sri Lanka

The first major Internet based service in Sri Lanka is email; *LEARNmail*, the academic and research email service run by LEARN, being the only such service for a number of years since its inception in 1990. This was followed by restricted access to data bases, library catalogues, information resources, etc. outside the country for academic and research purposes. With the interconnection of LEARN sites online using Internet Protocol (IP) technology in 1994, *remote login* and *file transfer* became common services. Around the same time the first ever *world wide web* server in Sri Lanka was launched by the Department of Computer Science & Engineering of the University of Moratuwa⁴⁶.

Today most universities in Sri Lanka have set up web servers to provide essential information about the university including information about Faculties, Departments, Staff, Services, etc. Some universities are planning to use the web to deliver teaching and learning materials to the students. Although students in traditional universities, where face to face teaching takes place, can benefit from this, the distance education approach taken by the Open University is bound to make the most out of this exercise.

The interest by the commercial sector was seen in Sri Lanka only after the Internet based services for the academic and research community were stable for a number of years. Although email and Bulletin Board Services (BBS) were offered on a commercial basis from about 1993, the first attempt to bring online Internet technology and its associated online services occurred in mid 1995 when Lanka Internet Services was set up with US-AID collaboration. Since then Sri Lanka has seen the proliferation of Internet and its services on a large scale through a number of commercial ISPs in addition to LEARN, although many are still confined to Colombo and suburbs due to the restricted availability of telephone connectivity and affordability.

Already a couple of *Cybercafes* have sprung up in Colombo to cater to those who do not have either dedicated or dial up access to the Internet through an ISP. These also serve as Internet kiosks for tourists and travelling businessmen. At these kiosks email and web access are provided for a fee.

Internet Phone, which facilitates voice and video communication over the Internet, is a service which is gaining popularity as a cheap alternative to the traditional telephone service. Internet Telephony will be a major threat to the traditional telecom operators and it is expected that this will cause an explosive growth similar to, if not bigger than, the use of the web on the Internet.

Despite the short existence of Internet based business, Sri Lanka has an impressive array of Internet based services, especially the services based on the world wide web technology. For example many popular daily and weekend newspapers are available on the Internet in Sinhala⁴⁷, Tamil⁴⁸ and English⁴⁹. Some of these web sites offer Sinhala and Tamil fonts necessary to read the newspapers free of charge. There are many web service providers who provide searchable access to Yellow Pages, Business Directories, etc.

In order to facilitate decision making in import/export trade based on timely world market situations, the Ministry of Internal & External Trade has initiated TradenetSL⁵⁰, a web based service. This site provides among other things Trade Information, Trade Statistics, Trade Inquiries and links to other Trade Web sites. The Sri Lanka Export Development Board⁵¹ and Chamber of Commerce in Sri Lanka⁵² have web sites which offer services to the exporters.

There is also an official national web⁵³ site which provides links to some state sector and other organisations such as:

- * Central Bank of Sri Lanka
- * Board of Investment
- * Trade & Commerce
- * Export Development Board
- * Tea Board
- * Colombo Stock Exchange
- * Lanka Business Web
- * Banks and Insurance.

*Avakasa Kade*⁵⁴, Sri Lanka's first *shopping mall* in cyberspace provides web based access to more than 1500 product items falling into 20 product categories supplied by over 60 companies which can be ordered through the Internet and paid for by popular credit cards. In addition it offers a service which allows on line payment for electricity supplied by the Ceylon Electricity Board, water bills, Medicalls (Pvt) Ltd bills and ITMIN dialup charges. *Avakasa Kade* claims to be the first in Sri Lanka to provide secure credit card transactions on the Internet.

A *Virtual Post Office*⁵⁵, which works as a clearinghouse to send and receive web based cards, with links to pages describing the services of the Sri Lanka postal service, is also available. A more complete account of Internet based services can be found in reference 56.

Although World Wide Web is a very powerful medium for the quick dissemination of information on the Internet, its use must be carefully organised for maximum impact. For instance many sites do not stay up-to-date and most web pages contain dead links. Therefore it must be the responsibility of the information owner and/or the information service provider to make sure that his site provides current and accurate information.

Moreover some sites do not carry the information about, and links to, the sites which are relevant to their own activities. Therefore it is very important that the web servers are kept constantly updated. What is seen in many cases is the addition of a web site, which is forgotten after the initial enthusiasm dies down. It must be understood however that this is detrimental to the growth of the Internet based business in Sri Lanka and must be avoided.

IT in Banking and Finance

The penetration of IT into financial and banking sectors in the last few years has been phenomenal. The widespread availability of IT and its use in the stock and commodity broking, insurance and banking and complex funds and currency

management has expanded the world's financial markets. The deployment of IT in the financial markets has enabled the collection of market data and intelligence, and together with sophisticated analytical tools the ability to monitor, assess and even predict market movements. IT in conjunction with improved communications has been a major factor in the globalisation of operations generating massive overseas interests in investments in the financial markets.

The continued application of IT and networked communications in the financial markets has led to the concept of global electronic 'virtual market place', for the conduct of every form of electronic commerce imaginable. This will no doubt lead to far reaching social and political implications, in addition to more obvious commercial ones.

The Banking sector in Sri Lanka was quick to realise the need for sophisticated information systems in banking. The commercial banks as well as state banks started computerisation of the back office operations and then the front office operations, which had resulted in making the banking system in Sri Lanka very efficient. Banking is also one of the application areas which had used data communication infrastructure for interbranch communication for a long time. In the absence of a data communication service offered by the public carrier (Telecommunications Department at that time), the banking sector encouraged the growth of dedicated private networks for banking using radio technology operated by private sector operators.

Using this infrastructure, many banks were able to link their branches together and offer services such as ATM (Automatic Teller Machines) for the convenience of their customers. Once the necessary information systems and the data communication infrastructure were in place, the Sri Lankan banking system was able to integrate world wide services such as SWIFT (Society for Worldwide Interbank Financial Telecommunication) for efficient international transactions. In June 1994, Sri Lanka joined the SWIFT service which is used by more than 3000 financial institutions in over 80 countries in the world. SWIFT is a sophisticated automatic message exchange system for financial transactions providing instantaneous communication with reduced risk of miscommunication and increased security. More than 15 banks in Sri Lanka benefit from the introduction of SWIFT, the largest financial telecommunication network in the world.

Today, customers enjoy the benefits of the use of Information Technology in banking. Such an up-to-date banking and finance system is absolutely essential if Sri Lanka is to develop itself into a commercial and trade hub of South Asia.

IT in Trade and Commerce

The 1990s is the decade in which Information Technology enabled rapid growth in global trading. In the modern business world it is therefore imperative that necessary facilities are provided to support efficient business transactions to facilitate national and international trade and commerce. Along with liberalised banking, finance and trading law, the availability of *Electronic Data Interchange* (EDI) service, which refers to the exchange of structured messages from one computer to another to allow those engaged in trade and commerce to transact their businesses efficiently, is a critical factor for the success of Sri Lanka as a regional commercial hub.

EDI was first initiated in Sri Lanka by the Computer and Information Technology Council (CINTEC - now Council for Information TEChnology) and SLEDB (Sri Lanka Export Development Board) in 1987. Over the years necessary legal and standards frameworks have been put into place. An important step in this direction is the establishment, by CINTEC in 1995, of a Working Group to function as a National EDI Forum with the following Terms of Reference:

- * Formulate and implement a national policy on Electronic Data Interchange (EDI).
- * Establish and implement a national EDI system.
- * Promote, facilitate and assist, the use of, and the application of, EDI in Sri Lanka.
- * Develop and improve the infrastructural facilities necessary for the introduction of EDI to Sri Lanka.
- * Recommend to the Government measures to advance the skill and knowledge of persons involved in all sectors of EDI.
- * Promote the use of EDI nationally and internationally.
- * Recommend the establishment of facilities for EDI among relevant institutions.
- * Promote the conduct of research on all aspects of EDI.

Among the important milestones in the promotion of EDI activities in Sri Lanka are:

- * Sri Lanka Ports Authority (SLPA) has set up its EDI network, MARINET, linking SLPA and shipping agents.
- * CINTEC has worked on the legal aspects and also on the data communication infrastructure, and has initiated an integrated banking network with a shared Automated Teller Machine (ATM) switch which will form an interbank EDI system.
- * The Sri Lanka Standards Institution (SLSI) has approved some of the UN/EDIFACT (EDI For Administration, Commerce and Transport) standards.
- * Sri Lanka became a member of the Asia EDIFACT Board (ASEB) in June 1995.

The National EDI Committee has incorporated Sri Lanka EDI Network Services (Pvt) Limited (SLENS) as a company in March 1997 to establish, own and manage the network. Initially the members of SLENS would be the public sector organisations directly involved in trade and commerce. The shareholding is expected to be broad based later to include the private sector.

The current EDI users include:

- * Sri Lanka Ports Authority
- * Shipping lines and shipping agents (more than 15 companies use EDI)
- * Freight forwarders (about 100 companies in Sri Lanka)
- * Sri Lankan Airlines (formerly Airlanka).

In recognising that EDI brings a new dimension to criminal law, the necessary amendments to the applicable laws have been undertaken by the CINTEC IT Law Centre which is in the process of developing and reforming laws that are required for the use of EDI in Sri Lanka. It has already finalised the criminal law and has examined specific issues relating to EDI including commercial and contractual laws and the need to establish proper regulations and guidelines.

IT and Legal Implications

The free flow of information through the Internet and its use in trade and commerce have raised complex legal issues across the world. The impact and relevance of these issues to Sri Lanka are being addressed by the IT Law Centre of CINTEC.

With the proliferation of digital electronic information and communication media, it has become necessary to examine the legal implications of the use of such information and communication media for business, trade and commerce and develop a suitable judicial framework to positively encourage the integration of Information Technology as a product, service and a trade into the socio-economic environment of Sri Lanka. Sri Lanka is now in the process of reforming and developing the legal infrastructure to make it receptive to *Electronic Commerce* and other dimensions of digital electronic related modern human activity.

In 1995 Sri Lanka introduced the Evidence (Special) Provisions Act. This is the only law in Sri Lanka that deals specifically with electronic dimension of modern human activity and provides for the admissibility of information produced by computers and other electronic devices in a court of law. The law also provides for presumptions and procedures facilitating the efficient handling of admissible information whilst enabling the opposing party to challenge and inspect the information sought to be produced under the said Act. It is clear that this Act has to undergo more comprehensive reforms in order to accommodate modern dimensions of Electronic Commerce.

Sri Lanka has also embarked on the reform of its Penal Laws 1994 and this initiative has resulted in the Proposed Computer Crimes Act which was presented to the public in September 1997. The basis of the Proposed Computer Crimes Act is to criminalise attempts at unauthorised access to a computer, computer program, data or information. It also contains provision to deal with unauthorised use of computers regardless of whether the offender had authority to access the computer.

The proposed Act creates offences for unauthorised modification, alteration or deletion of information and denial of access, which makes it an offence for any person to program the computer in such a manner so as to prevent authorised persons from obtaining access. Other offences include causing damage or harm to the computer by the introduction of viruses and logic bombs etc., unauthorised copying of information, unauthorised use of computer service and interception of a computer program, data or information while it is being transmitted from one computer to another, unauthorised copying and abstraction of data or information, eavesdropping, sabotage and espionage, and introducing pornographic material of gross indecency.

Special procedures for the investigation and prosecution of these crimes have been incorporated together with provisions enabling the appointment of experts to investigate crime and the designation of an appropriate institution to monitor and co-ordinate the implementation of the Law. Provision has also been made in the Proposed Computer Crimes Act to provide for extra territorial jurisdiction bearing in mind that territorial boundaries do not exist in a contemporary IT environment.

Data Protection

The ever increasing amount of personal, business and other information held by various governmental and non-governmental organisations has necessitated new Data Protection legislation.

Sri Lanka does not have comprehensive Data Protection Legislation and a study has been recently commenced to propose legislation using the UK Data Protection Act of 1998 and the EC directive on Data Protection as templates. In the meantime provision has been made in several Computerisation Contracts to protect the confidentiality of both the Buyer and the Seller. The Banking Act of 1988 also contains secrecy provisions.

Intellectual Property Rights

Several Intellectual Property Rights issues have arisen in the contemporary IT environment. Electronic infringement of Property Rights are becoming common and there are particular legal and ethical issues arising from the use of *Domain Names* and other virtual properties in the Electronic Environment. Unlike *Trade Marks*, the one who gets a domain name registered acquires a monopoly for all the goods and services on the Internet consequent to that registration.

Many legal issues have arisen in relation to the wide spread use of the Internet which is a borderless medium for the transmission of information. Critical data and information is being transmitted across the globe in a virtually unregulated environment. The Internet is now increasingly being used for commerce and will be used widely even for banking in the near future. The Banking regulators in Sri Lanka have taken a hands-off approach to the regulation of new technology. Even ATMs and remote service units are no longer treated as branches of commercial banks.

IT Policy and National Issues

Background

The policy pronouncement by HE the President J R Jayewardane at the convocation ceremony of the Vidyodaya University in the early 80s is of considerable importance since it formed the basis of IT policy development in Sri Lanka. This was soon followed by the appointment of the Computer Policy (COMPOL) Committee at NARESA (now NSF) headed by Prof Mohan Moonesinghe who at the time functioned as the Energy Advisor to HE the President. The recommendations of the COMPOL committee resulted in establishing the Computer and Information Technology Council (CINTEC - now Council for Information Technology) as the apex body responsible for the development and promotion of IT in the country. The emphasis placed by the government on the promotion of IT is evidenced from the fact that CINTEC at that time was placed directly under the purview of HE the President.

Aided by the open economic policies of the government, the Sri Lankan IT industry grew rapidly with the installation of large computing systems in a number of key areas of the economy. Some of these include the Cheque Clearing House of the Central Bank of Sri Lanka, Colombo Stock Exchange, Container Transshipment System of the Sri Lanka Ports Authority, State and Commercial Banks and more recently the Apparel Industry, which in recent years has become the largest revenue earner for Sri Lanka.

The role of CINTEC

CINTEC²⁷ from its inception concentrated on important national IT issues such as the development of the Sinhala Code for Information Interchange, to be incorporated as an international standard by the ISO. Much effort has been expended to make sure that the Sinhala Code can co-exist with the Code for Tamil, which had already been proposed by India. This is to make some degree of transliteration possible. The immediate benefits from this exercise to the Sri Lankan public at large will be the availability of application packages and common user interfaces in the national languages. CINTEC also took the leading role in preparing IT Glossaries. However, Sri Lanka must not lose sight of the fact that in the IT industry English is still the

internationally accepted language. This is very important in view of Sri Lanka's desire to enter into the global software market.

Some of the other important areas covered by CINTEC activities include the formulation of Evidence Law in the context of IT and the Intellectual Property Laws, the promotion of IT in the public sector and IT applications in major economic sectors including agriculture, banking and trade, manufacturing engineering, data communications, and human resources development.

CINTEC has actively supported the development of IT in schools and higher educational institutions by partaking in an advisory role in the Computer Education Project (CEP) of the Ministry of Education and the Sri Lanka Inter University Committee on Computing (SLIUCC) of the University Grants Commission (UGC). Its association with the CEP had resulted in setting up of the National Certificate in Computer Applications (NCCA) Examination. National Examination in Computer Studies (NECS) is a professional level examination promoted by CINTEC jointly with the Computer Society of Sri Lanka.

For the benefit of those sections of the public who do not have ready access to information on IT, a mobile computer unit set up by CINTEC visits different parts of the country on a regular basis sometimes coinciding with major public gatherings such as Mahapola.

State recognition of IT has resulted in the government of Sri Lanka declaring 1998 as the "Year of Information Technology". An International IT Conference (IITC '98) and INFOTEL '98 Exhibition were organised by CINTEC in 1998 to mark this occasion. The success of the above activities has led CINTEC to declare a three year programme 1999 - 2001 to be called "IT 2001" and to organise IITC '99 and INFOTEL '99 as associated events.

As part of CINTEC's drive to educate the youth, CINTEC has trained and sponsored talented youth for the International Olympiad in Informatics (IOI) held annually and had been rewarded when our contestants had won a gold (1995), silver (1994, 95) and a couple of bronze medals (1996). In the same spirit CINTEC has assisted the CSSL in training young contestants for the SEARCC software competition which was won by Sri Lanka in 1995 after becoming runners up in Karachi in 1994. Since 1990, the CSSL has held the Inter School Software Competition through which the national team for the annual SEARCC software competition is chosen.

For the banking sector, CINTEC has laid the foundation for a common ATM (Automatic Teller Machine) network, and for the benefit of the trade sector in Sri Lanka CINTEC has been instrumental in setting up the Sri Lanka EDI (Electronic Data Interchange) Association to allow efficient international trade to take place.

In acknowledging that access to telecommunication and data communication services is becoming one of the minimum necessary conditions for active participation in domestic and international markets, CINTEC has been consistently pushing the Department of Telecommunication (which later became Sri Lanka Telecom and now SLT Ltd) and the Telecommunications Regulatory Commission to enhance communication infrastructure in Sri Lanka. After recognising the importance of LEARN for the academic and research community in the country, CINTEC had been funding LEARN at various stages, the most notable being, bearing the cost of the leased line from LEARN to the Internet in 1995.

CINTEC has been active in the promotion of commercial Internet in Sri Lanka. Along with the US Agency for International Development (USAID) a round table on Internet was organised in 1993, the outcome of which helped the first commercial ISP to commence business in Sri Lanka in 1995.

The Sri Lanka Computer Vendors Association (SLCVA), Sri Lanka Association of Software Industries (SLASI) and the Association for Computer Training Organisations (ACTOS) were all formed by the initiatives of CINTEC. They have now formed into the Federation of IT Industry in Sri Lanka (FITIS) with a common goal of helping the IT industry in Sri Lanka to grow.

Software export: a missed opportunity?

It is generally agreed that one of the opportunities for Sri Lanka to achieve economic prosperity is by developing a strong software export industry, but the country has been slow in building up this capability. Although the software export industry in Sri Lanka today must have grown many fold compared to what it was a decade back, it is still minute compared to the global demand for software, and also when compared with the export market captured by countries like India. It is publicly reported that India had earned a total revenue of US \$ 1.15 billion in 1996/97 from software exports and targets to reach the US \$ 3.6 billion mark by the year 2000¹⁹.

In this context it is also worth noting that statistics are not readily available to support a claim that Sri Lanka's software industry is growing, except for the intuitive feeling from the size and revenue of some of the companies involved in the export of software. However it is encouraging to realise that some effort has been successfully put in for the import substitution of application software by locally developed packages. This must be positively encouraged as it not only helps to save valuable foreign exchange but because it helps to improve the ability to produce good quality software locally, coupled with a better software maintenance service to the customers.

A survey carried out in 1997⁵⁷ has revealed that of a total business application software sales amounting to Rs 265 million (US\$ 5 million) only 47% has been locally

developed. However it is interesting to note that in 1996 alone, of a total of Rs 116 million (US\$ 2 million), 73 % of the software had been locally developed, indicating that the locally produced software is gaining popularity. In comparison the domestic software market in India has been US\$ 700 million in 1996/97. India has set a target of US\$ 2.5 billion in the year 2000¹⁹.

As seen from Figure 15, the largest demand for software developed in India is from the US. The global software market in the year 2000 is believed to be of the order of US\$ 400 billion and the US will continue to dominate with the largest share. Therefore Sri Lanka must strive to enter the US market. However, Sri Lankan software companies suffer from the lack of experience and exposure to business conduct in the US market. This is made even worse by the fact that many companies in Sri Lanka have operated within a largely non-competitive domestic software industry. If Sri Lankan software companies have to succeed in a market as sophisticated as the US market, a significant training effort is needed in business communications, practices, processes and market expectations.

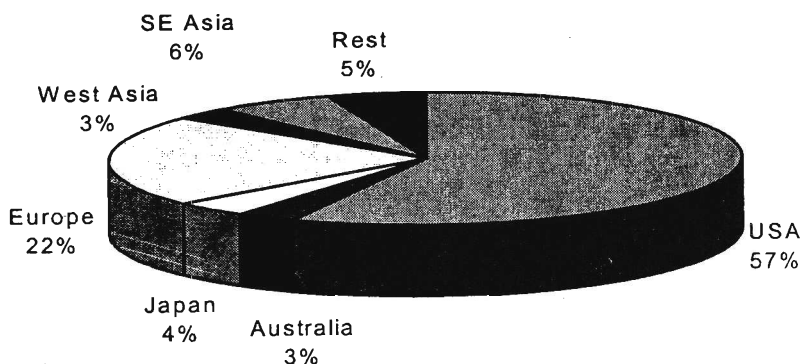

Figure 15: Indian software exports by destination

Therefore Sri Lanka has to invest up-front in providing suitable training opportunities in marketing and sales, project management and business analysis and more importantly US style business communications. This must be done within a framework of a national vision for IT development. In parallel an image building and awareness raising effort in the US market must be undertaken. It must be clearly understood that the window of opportunity for Sri Lanka is small and if it is missed now, it will never be got again.

Conclusion

IT is the result of the marriage of *computer and communication (C & C)* technologies. Today, a third but related dimension, *Information*, is brought in thus widening the scope and highlighting the close knit nature of Information, Telecommunication and Computers (ITC). ITC further emphasises the importance of telecommunications in the new information society.

IT has the dual characteristic that, it is a technology by itself and a technology which plays a pivotal role in the successful development of other economic sectors. In today's context, IT must be used to enhance the productivity of agricultural, industrial, financial, commercial and other sectors. At the same time IT as a technology itself, must be fully exploited. It is through this two - fold strategy that Sri Lanka should aim to sustain a growth rate comparable with the growth rates of the emerging economies in the region.

The new and emerging society depends to a great extent on computers and computer networks for their day to day survival. There had been no other era that the human civilization is so much dependant on the safety, security and comfort afforded by IT; and there is no turning back. If computers and computer networks are switched off there is a good chance that there will not be food, water, sanitation, heat, light, power, transport or clothing for the major part of the world's population.

The deployment of technologies such as Low Earth Orbit (LEO) satellites which promise to meet the demand for any amount of line bandwidth to any location in the world for easy and economic access to the Internet, will have a major impact on the operations of the traditional telecom operators. Today, satellite constellations are bringing voice communication services to the entire planet. Tomorrow, they will deliver a host of interactive, multimedia communications options on a global scale. These type of projects and services with their ability to make an unprecedented impact on the rural sector of the developing world will bring us more closer to making the concept of a "global village" a reality. The facilities thus made available are certain to revolutionise the way the world has been used to carry out its business of living for two millennia.

References

1. Induruwa A.S. (1984). Towards an information society in Asia. *Bulletin of the Asian Regional Exchange for New Alternatives, Special Issue on Policy and Planning* 3 (2&3); 49-59.
2. Induruwa A.S. (1984). Computer literacy – a vital need for development. *Proc. Symposium on the Role of Computers in Education and Commerce, University of Moratuwa, Sri Lanka.*

3. Dearing R. (1997). Report of the National Committee of Inquiry into Higher Education. *Report submitted to the Secretaries of State for Education and Employment, UK*. (<http://www.leeds.ac.uk/educol/ncihe>)
4. World Wide Web Consortium (<http://www.w3.org>)
5. Iridium (<http://www.iridium.com/>)
6. Globalstar (<http://www.globalstar.com/>)
7. SkyBridge (<http://www.skybridgesatellite.com/>)
8. Teledesic (<http://www.teledesic.com/>)
9. Williamson M. (1999). Can satellites unblock the Internet?. *IEE Review*, May, 107-111.
10. Corey K.E. (1995). Information technology and telecommunications policies in South East Asian development: cases in vision and leadership. (<http://ifrm.glocom.ac.jp/doc/c01.001/txt1.html>)
11. IT 2000 – Singapore’s vision of an Intelligent Island (<http://www.ncb.gov.sg/ncb/vision.asp>)
12. Vision 2020: Malaysia’s Multimedia SuperCorridor (MSC). (<http://mdc.cinenet.net/>)
13. Samaranayake V.K. (1998). Fifty Years of Information Technology. In: *Fifty Years of Sri Lanka’s Independence: A Socio Economic Review*. (Ed. A. D. V. de S. Indraratne). Sri Lanka Institute for Socio Economic Studies; 417-431.
14. Reeves C. (1983). Introduction of computing to degree studies in Sri Lanka. *Report to the University Grants Commission, Sri Lanka*.
15. University of Moratuwa, Sri Lanka. (1983). *University of Moratuwa Computer Policy*.
16. Induruwa A. S. & Hawksley. C. (1990). A development programme for computing in Sri Lankan Universities. In: *Computers in Education*. pp 769-774. Elsevier Science Publishers BV (North Holland).
17. Induruwa A. S. (1987). Computer science & university education. *Proc. Tech. Sess. Seventh National Computer Conference, Sri Lanka*; 105-108.

18. Induruwa A. S. (1992). Challenges in developing a curriculum in computer science & engineering - Sri Lanka's Experience. *International Journal on Engineering Education* 8(1); 36-42.
19. NASSCOM – National Association of Software and Services companies of India (<http://www.nasscom.net.in>)
20. LEARN - Lanka Educational And Research Network (<http://www.learn.ac.lk/>)
21. Induruwa A. S. (1989). LEARN – Lanka Experimental Academic and Research Network (Version 1.0). *A proposal to the government of Sri Lanka*. (<http://www.cs.ukc.ac.uk/people/staff/asi1/learn/learn-v1.html>)
22. Induruwa A. S. (1989). Is Sri Lanka ready for wide area computer networking?. *Transactions of the Institution of Engineers, Sri Lanka*: 163-171.
23. Induruwa A. S. (1989). The importance of tele-informatic services in an evolving information society. *Transactions of the Institution of Engineers, Sri Lanka* :151-162.
24. Induruwa A. S. (1992). Introduction of internet services for the academic and research community in Sri Lanka (LEARN Ver 2.0). *Report to the Sri Lanka Inter University Committee on Computing (SLIUCC), University Grants Commission* (<http://www.cs.ukc.ac.uk/people/staff/asi1/learn/learn-v2.html>)
25. Adams C. W., Amarasiri S., Dias G. & Induruwa A. S. (1992). Implementing computer based communication services in Sri Lanka. *Proc. Twelfth National Computer Conference, Sri Lanka*: 107-121.
26. Firdhous M. F. M. & Dias. G.V. (1996). The Introduction of Internet in Sri Lanka. *Proc. Fifteenth National IT Conference, Sri Lanka*: 150-154.
27. CINTEC - Council for INformation TEChnology (<http://www.lk/national/cintec/cintec-index.html>)
28. SLNet (<http://www.lacnet.org/slnet/>)
29. LAcNet - Lanka Academic Network (<http://www.lacnet.org/>)
30. NSF - National Science Foundation of Sri Lanka (<http://www.naresa.ac.lk/>)
31. SuperJANet – The UK academic information super highway (<http://www.ja.net/>)

32. Induruwa A. S. (1998). Globalisation of the Internet – Sri Lanka's contribution. *ADB/ITU Seminar on Telecommunication and Information Technology: Tools for Sustainable Development in Asia, Geneva, Switzerland*. (<http://www.cs.ukc.ac.uk/people/staff/asi1/learn/adb-itu98.html>)
33. Kularatne A. D. V. N. (1998). Telecommunications development in Sri Lanka: an independent assessment. In: *Fifty Years of Sri Lanka's Independence: A Socio Economic Review*. (Ed. A. D. V. de S. Indraratne). Sri Lanka Institute for Socio Economic Studies: 432- 458.
34. Gunaratne S. (1997). Sri Lanka and the third communication revolution. *Media Asia*. **24**(2); 83-89.
35. Hobbes' Internet Timeline (<http://www.isoc.org/zakon/Internet/History/HIT.html/>)
36. Internet Domain Statistics (<http://www.domainstats.com/>)
37. Induruwa A. S. (1991). Fast packet switching technologies suitable for multi media global connectivity. *Proceedings of the Eleventh National Computer Conference, Sri Lanka*: 74-83.
38. Induruwa A. S. (1991). Wide area computer networking: a strategic opportunity for developing countries. *Proceedings of the Eleventh National Computer Conference, Sri Lanka*: 151-162.
39. Mansell R. (1993). *The New Telecommunications – a political economy of network evolution*. SAGE.
40. TEN-155 – Trans European Network: the information superhighway for European R & D. (<http://www.dante.org.uk/>)
41. Induruwa A. S. (1998). Managing and operating HE & R networks in the UK-recent trends. *International IT Conference '98, Colombo, Sri Lanka*. (<http://www.cs.ukc.ac.uk/people/staff/asi1/iitc98/uk-trends.html>)
42. JISC Network Services. (<http://www.jisc.ac.uk/>)
43. Induruwa A. S. (1995). Research information infrastructure in Sri Lanka – current status and future plans. *Association for Science Corporation in Asia (ASCA), Tokyo, Japan*. *

44. Induruwa A. S. (1996). High Performance Computing – The next wave of IT development for Sri Lanka. *Proc. Fifteenth National IT Conference, Sri Lanka: 10-25.* (<http://www.cs.ukc.ac.uk/people/staff/asi1/cssl/papers/hpc.html>)
45. ITMIN - Industry, Trade & Market Information Network (<http://www.itmin.com/>)
46. Induruwa A. S. (1994). Advances in computer networking in Sri Lanka. *Trans. IEE Sri Lanka Centre.*
47. Lankadeepa - Sinhala Daily News Paper (<http://www.ccom.lk/lankadeepa/>)
48. Virakesari - Tamil Weekly News Paper (<http://www.ccom.lk/virakesari/>)
49. Sunday Times - English Weekly News Paper (<http://www.lacnet.org/suntimes/>)
50. TradenetSL - (<http://www.tradenetsl.lk>)
51. EDB - Export Development Board (<http://www1.tradeaccess.com/edb/>)
52. Ceylon Chamber of Commerce - (<http://www.lanka.net/chamber/>)
53. Sri Lanka National Web Site - (<http://www.lk/>)
54. Avakasa Kade - Internet shopping mall (<http://www.avakasakade.com/>)
55. Virtual Post Office - (<http://www.lanka.net/postoffice/>)
56. Induruwa A.S. (1991). Internet based services *Proc. International IT conference 199, Colombo, Sri Lanka.*
57.  Lanka Market Research Bureau Limited. (1997). Information industry. *Report on a Market Research on the Computer Industry.*