

NA-131

# Science Investigations

විද්‍යා ගවේෂණ  
විஞ්‍යාන ජ්‍යෙෂ්ඨයන්

NA-131

NUMBER 2

JUNE 1982

Published by  
THE NATURAL RESOURCES, ENERGY AND SCIENCE AUTHORITY OF  
SRI LANKA

# SCIENCE INVESTIGATIONS

විද්‍යා ගවේෂණ

விஞ்ஞான ஆய்வுகள்

NUMBER 2

JUNE 1982

---

Published by  
THE WORKING COMMITTEE ON SCIENCE EDUCATION,  
NATURAL RESOURCES, ENERGY AND SCIENCE AUTHORITY OF SRI LANKA,  
47/5, Maitland Place, Colombo 7.

## EDITORIAL

The main purpose of *Science investigations* is to provide a medium for the publication of simple pieces of scientific investigation and research done in Sri Lanka. Anybody may send in contributions for publication. School pupils and school teachers are particularly welcome. Contributions may be made in any branch of science.

Number 1 was published in June 1981. The articles were in Sinhalese or English. (No Tamil material was received.)

The present issue, number 2, is entirely in English. The articles are mostly on biological topics and they all come from the Kandy region. The reason for these peculiarities is simply that the material has come from a series of 'Investigation Group' meetings which the present editor ran in Peradeniya over a number of years.

A notice to contributors was published in English, Sinhalese and Tamil in issue no. 1.

Contributions should be sent to :

The Editor,  
Working Committee on Science Education,  
Natural Resources, Energy and Science Authority,  
47/5, Maitland Place,  
Colombo 7.

V. Basnayake  
*Editor*

Professor of Physiology, Faculty of Medicine, University of Peradeniya.  
Hony. Director, Working Committee on Science Education, Natural Resources, Energy and Science Authority of Sri Lanka (NARESA).

## CONTENTS

	<i>Page</i>
Akuressa, S. Batalagala (Bible Rock) .. .. .	1
Atapattu, C., Cuncheer, S. S. & Ilukkumbura, A. K. Time of day at which flowers open and the duration for which they stay open : pagoda flower ( <i>Clerodendron paniculatum</i> , S. pinna) and two jasmynes ( <i>Jasminum humile</i> , saman pichcha), ( <i>Jasminum sambac</i> , S. getapichcha). .. .. .	9
Dias, D. D. Firefly light and the weather. .. .. .	18
Dias, D. D. & Weerasinghe, A. Relationship between distance and time in athletic sprinting. .. .. .	20
Dissanayake, A. Spirals of the tendril of the orange bignonia. ..	24
Dissanayake, A. Pleasant/unpleasant response to the odour of lantana flowers, guava leaves and maduruthala (basil) leaves. ..	25
Ekanayake, G. Variation in the number of petals of flowers. ..	27
Fernando, S. Cracking sound on pulling or pressing on the fingers.	29
Gunaratne, P. B. Leaf veins and leaf size. .. .. .	32
Halangoda, L. B. & Hanwella, U. G. Growth of sugar cane. ..	34
Jayatileka, A. D. C. Earthworm's choice between turning left or right.	35
Kaluarachchi, P. S. Preference for shade or sun. .. .. .	37
Kathirgamarajah, M. Food and feeding in a pond. .. .. .	39
Kotakadeniya, S. R. B. Paralysis of one side of the body in a bird. ..	44
Palipane, J. White soil of Wattedgama : suitability for making chalk and pipe-clay. .. .. .	45
Weerasinghe, G. W. R. Pattern and growth of the tendrils of the pumpkin creeper. .. .. .	47

## BATALAGALA (BIBLE ROCK)

S. Akuressa\*

### Introduction

Batalagala (Bible Rock), 870 metres above sea level, is a square-cut mass of rock in the Aranayake area. The Dutch called it Coffin Rock "because it is long and narrow" (Heydt, 1744). It is a striking sight on the way from Colombo to Kandy by road or rail. To reach it, the traveller takes the road from Mawanella to Aranayake for a distance of about 9 km from Mawanella. On the way, he passes Ussapitiya from where there is a fine and majestic view of the rock. He turns off either at Ambadeniya Group, which reaches the east face of the rock, or at Gawilipitiya which reaches the west face from the village of Hathgampola on the Gawilipitiya - Kegalle road.

The rock rises sheer, with a shape like that of a monster loaf of bread. The long axis, about 0.5 km long, lies in a north-south direction. The north and south faces drop sheer to a base which continues northwards and southwards respectively as a low range of hills. The east and west faces slope sharply down, like the flanks of an elephant, to reach a base which slopes more gently along cultivated land. The top of the rock is relatively flat with a width of about 15 metres.

The rock is windswept, especially its northern end. Much of the rock is bare; this is wholly so for the north and south faces, and it is partly so for the east and west faces. The bread-loaf shape and the bareness give the rock a striking sentinel-like appearance.

The rock can be climbed along its east face from Ambadeniya estate, or up the west face from Hathgampola. No equipment is necessary. Visitors to the rock, even parties of them, are frequent, and many names of individuals are seen inscribed on the rock at the top. But the climb is steep and requires

---

\* MS received in March 1981.

Miss Sujatha Akuressa, 24 years, Family Health Bureau, Kachcheri, Kandy.

Present address: Miss S. Akuressa, Unesco-Sri Lanka, Cultural Triangle, Jethavana Project, Anuradhapura.

nerve, a good foot and a guide. The villagers are helpful in acting as guides. There are a number of springs on the way up, at which the visitor can slake his thirst if he does not mind the tadpoles which abound in the pools.

### Method

I record here my casual impressions from climbing Batalagala on 14 March 1981. I climbed from the west side, both in going up and coming down. I am told that the east side climb is even steeper.

### Results

The climb could be divided into three parts:

1. The foothills with Hathgampola village.
2. The foothills with rain forest.
3. The rock itself.

1. *The foothills with Hathgampola village* consist of cultivated land, with paddy and coconut, and now cloves. The paths are constructed of granite stairways. I saw a potter wasp snatching and carrying away a small spider from one of the stairways.

The village consists of Sinhalese families, all closely related. The men, women and children are of attractive appearance, and they are helpful to the visitor. I greatly enjoyed the kurumba water which they freely gave me to drink.

I saw a chocolate-brown butterfly with black spots on its forewing and a black band along the bottom edge of its hind wing. The body was about 2.5 cm long, wing height about 2.5 cm. It was probably a nymph.

The streams contained the common carp-like *Labeo* (S. Kanaya) and blackish-brown frogs with bodies about 5 cm long.

The tree *Careya arborea* (S. Kahata) was common, It was in flower, giving a sickly sweet odour to the air ; masses of flowers lay under the trees. Agave grew luxuriantly on the rocks.

2. *The rain-forested foothills* are covered with trees and lianas, except where some rubber was being grown and where abandoned chenas gave an

air of desolation to the scene. The grass that grows in the clearings is chiefly *Imperata cylindrica* (S. illuk) and *Setaria* sp. (S. janapadanattan), both with bottle-brush like inflorescences.

The rain forest is shady, dim and cool. Crickets were singing there at noon. Much of the forest is of secondary growth containing stands of the semi-shrubby *Strobilanthes* sp. (S. nelu) which was not in flower; *Lantana camara* var. *aculeata* (S. ganda paana), and numerous saplings of *Wendlandia bicuspidata* (S. rawan idala), in which masses of the white-flowered inflorescences were beginning to appear and the leaves were full of galls. The saplings are used for rafters. I saw a man carrying a pile of rawan idala rafters on his head. Other trees in the secondary growth included *Mallotus albus* (S. bookaenda), *Melia dubia* (S. lunumidella), *Alstonia macrophylla* (S. hawari nuga); and *Acronychia pedunculata* (S. angkaenda) with smooth green globular fruits, the size of limes, attached without stalk to the branches; and mahogany (*Swietenia macrophylla*) and *Michelia champaca* (S. sapu).

The rain forest, including that seen on the eastern side of the rock had trees and lianas. The trees were of many different species, most of which I could not identify. There were *Macaranga peltata* (S. kaenda), *Ficus fergusonii* (S. nuga), *Terminalia belerica* (S. bulu) bursting into new red leaf, *Diospyros* sp. (S. Kadumberiya, an ebony), *Semecarpus nigroviridis* (S. badulla), and *Michelia champaca*, (S. sapu).

The lianas included *Entada phaseoloides* (S. poos wael) with their fantastic thick stems showing cork-screw spirals and spanning widely overhead from tree to tree; they were in flower, with cone-shaped spikes about 10 cm long consisting of a mass of small white flowers. The fruit of these small flowers is, however, the world's largest pod, measuring some 50 cm in length, but at Batalagala pods were few and about half that size. Another fantastic climber was *Smilax prolifera* (S. Kabarossa) with leaves entire, 20 cm long, thick and dark green, and the petiole thick and bent at a right angle, a long tendril arising at the bend and fixing the plant to other plants. The stem is thorny.

#### **Insects.**

There was a profusion of butterflies in the forest. The commonest larger kinds were the common crow (*Euploea*), the mottled emigrant whites and yellows (*Catopsilia pyranthe*) large swallowtails with two rows of red markings on the hindwing, *Papilio*, the common mormon or *Polydorus*, the common

rose; and the flashy blue patched peacock (*Papilio crino*), I saw two separate cases of mating in the red swallowtails. Both were seen in the afternoon at about 15.30h. In each case the pair consisted of a flying butterfly and a resting butterfly attached to the underside of the flying one; the wings of the resting butterfly were held together and hung downwards from the body.

Red hemipteran bugs were common among the rocks. Some were about 0.5 cm long, others about 1 cm.

### **Birds**

Bird song was plentiful in all of the foothills. I heard the barbet, kingfisher, magpie-robin, grackle, and the brahminy kite (*S. ukussa*). The kites were gliding overhead, even over the top of the rock.

### **Arachnids**

Tube webs were common. They consisted of a cylindrical tube, about 10 cm long, built in cracks in rocks or in the vegetation. The mouth of the tube is joined to a wide irregular web set in an oblique or vertical plane. This part of the web catches flying insects, while the tube is the spider's residence. This spider is very common in the Kandy region and elsewhere, but the Batalagala webs had tubes which were wider than those I have seen in Kandy. The mouth of the silken tube was thin and about 3 or 4 cm in diameter.

### **The rock itself**

Four main habitats occur on the rock :

- (a) Bare rock
- (b) Rock with grass tussocks and a few shrubs and stunted trees.
- (c) Forest
- (d) Caves

(a) *The bare rock* was extremely steep or sheer. The colour was brownish black on the exposed surface. The surface was granular and marked by a series of parallel close-set ridges separated by shallow furrows. These helped to give footholds for the climber. The rock becomes hot in the afternoon, giving a burning sensation to the bare foot. Large circular patches of grey lichen were extremely common on the rock.

(b) *Grass zones.* These occurred where the rock was less steep and contained ledges, so that soil had accumulated and had allowed the growth of a sparse vegetation. This consisted mainly of two kinds of grass: the large-leaved maana grass *Cymbopogon confertiflorus*, now mostly dry, and a shorter and acicular-leaved grass (*Chrysopogon sp.*) still managing to remain green in the inner leaves of the tussocks. The leaves of this grass were stiff and needle-like, tending to prick the foot but without necessarily drawing blood.

The *shrubs* were not identified. They were short and bushy; the leaves were thick, shiny, dark green. The *trees* were few; they were all *Careya arborea* (S. kahata), stunted, none being taller than 3 metres and most being much less; they were not flowering although their fellows in the foothills were full of blossom.

(c) *Forest.* The east face of the rock has two broad zones of rain forest extending all the way up from bottom to top. The vegetation which I could see by walking along the top edge of it was similar to that in the rain forest of the foothill zone of the west side.

Wild pigs are said to be numerous on the rock. We met a man with a double-barrel gun at the base of the rock. He was returning from the forest, empty-handed.

(d) *Caves.* The eastern face of the rock has a long ledge near the top of the rock. The ledge is covered with rain forest and it contains two large caves which are easily accessible from the top of the rock. I was told that there is yet another cave, also on the eastern face, filled with bats, and practically inaccessible. The two accessible caves had been used by ascetic Buddhist monks but were now abandoned.

The floor of the caves was sandy and contained the conical pits of the ant-lion larva (*S. bingkoonda*).

Water dripped from the walls of the larger cave. The thirsty visitor finds the clear water welcome, even if he has to take the water from a pool which has vegetation and tadpoles. Large numbers of bees continually visited the wet soil and pools. The bees were brown and about 15 mm long. The walls of the cave were covered with ferns. These were mostly *Cyclosorus*. Other ferns seen in the cave were *Nephrolepis* and *Adiantum sp.*

Spider webs. I saw two hemispherical orb webs in the caves, each about 50 cm in radius. No spider was seen.

## Discussion

*Rock.* Rocks like Batalagala, square-cut, isolated, standing far up above the level of the surrounding landscape, are common. Sigiriya and Yapahuwa are examples of this type. They are *erosion remnants* (monadnocks) (Cooray, 1967). One supposes that in the distant geological past the land surrounding the rock was at the same level as the rock. As time passed the erosive effect of rain water, wind, the sun's heat and the night's cold levelled down the land, leaving isolated erosion remnants like Batalagala because these happened to consist of extremely resistant rock. The erosive process gave them their steep sides.

## Vegetation

*Bare rock vegetation.* Only lichens grew on bare rock. The bareness was due to the steepness and wind. No soil could accumulate.

*The grass zone.* This was a zone which was somewhat less steep. Some soil had accumulated, allowing the grass and a few shrubs and stunted trees to grow. It was a xerophytic zone. Only the hardiest plants could survive, given a microclimate in which the rock became seasonally dry, with occasional bush fires, and always windy. Even the maana grass was dry and tindery at the time of my visit. The few shrubs and trees which do survive do so presumably by sending roots deeply into springs under the dry surface of the rock. The leaves of the shrubs and trees were dark green and leathery, thick, shiny. The thickness denotes extra water storage in the tissues of the leaf. The shine denotes a thick waxy cuticle which reduces transpiration. The dark green colour of the leaves of the shrubs is unexplained; it may be something peculiar to the species rather than an adaptation to the dry conditions. The stunting of the shrubs and trees is attributable to the desiccating effect of dry soil and strong winds.

*Rain forest.* Wherever a substantial depth of soil could accumulate, the climax vegetation would be rain forest in the wet zone of Lanka. This was the case in the ledges of the eastern face and in all of the foothills. Man is the chief enemy of these forests: he cuts them down for firewood or for gain.

'*Batala*'. The rock is said to receive its Sinhalese name, Batalagala, from batala, the Sinhalese word for the sweet potato. There is a legend that a king sought refuge on the rock and that batala was grown there as a source of food for him and his retinue. There is no trace now of batala or royal buildings on the rock.

*Fauna*. There was nothing unusual about the fauna except for the extraordinarily large size of the tube of the spider tube webs. The wasp which I saw capturing and carrying away a small spider was probably a spider wasp which falls into the category of mason or potter wasps which build earthen nests. The nest consists of separate cells, in each of which a paralysed spider is imprisoned to serve as food for the larva which develops from an egg deposited in the earthen cell. I have seen such a nest on the wall of the Field Centre building at the Peradeniya Teacher Training College.

The mating of butterflies involves a firm grasp of the female by the male with his claspers, "so that if the pair are disturbed they fly clumsily away together and settle down again elsewhere". In these circumstances, one individual hangs passively and is carried by the other, which may be the male or the female according to the species (Ford, 1957). In the mating which I saw of the red swallowtails there was no sign of any disturbance as being the cause of the flight nor was the flight clumsy. The time of day (afternoon) at which the mating occurred may also be worthy of note.

In built areas crickets usually chirp at night, from eventide to a little after sunrise. The chirping of the crickets at midday in the Batalagala forest was probably connected with the dimness of the rain forest.

### Summary

Casual observations of natural history made during a day's visit to Batalagala (Bible Rock) on 14 March 1981 are reported. The rock has three vegetational zones: a) bare rock with lichens only (b) xerophytic zone with grass and shrubs and stunted trees (c) rain forest where thick layers of soil had accumulated. Two caves on the eastern side were also visited. The tube of the common tube spider's web was unusually large in the forests of Batalagala.

### Acknowledgements

I thank Professor V. Basnayake for assistance with the writing of this paper.

## References

- Cooray, P. G. *An introduction to the geology of Ceylon*. National Museums of Ceylon. 1967.
- Ford, E. B. *Butterflies*. London: Collins. 3rd ed. 1957.
- Heydt's Ceylon*, (J. W. Heydt) 1744, translated with notes by. R. Raven-Hart. Colombo: Ceylon Government Information Department.

## TIME OF DAY AT WHICH FLOWERS OPEN AND THE DURATION FOR WHICH THEY STAY OPEN: pagoda flower (*Clerodendron paniculatum*, S. pinna) and two jasmines (*Jasminum humile*, saman pichcha), (*Jasminum sambac*, S. getapichcha).

C. Atapattu, S. S. Cuncheer and A. K. Ilukkumbura\*

### Introduction

Many flowers show a distinct daily rhythm in the time at which they open and the time at which they fade away. The morning glory (*Ipomoea learii*) is in full blue bloom in the morning and it fades away into a pink withering flower in the afternoon. The shoeflower (*Hibiscus rosa-sinensis*) opens in the morning and withers in the evening. The four o'clock flower (*Mirabilis jalapa*, S. hendirikka) opens in the afternoon and withers the next morning. A less obvious example was described by Eriyagama (1971) for the common weed *Elephantopus scaber* (S. Ath-adi) ; this little purple inflorescence opens at noon and closes the same afternoon. We wished to examine three common plants with regard to the daily rhythm in their flowering, for which we had no information.

- (a) Pagoda plant, (*Clerodendron paniculatum*, S. pinna). This extremely common 'weed' plant, between herb and shrub in size, is called the 'pagoda plant' because it bears a pagoda-shaped (conical) paniculate inflorescence at the top end of the plant. The 'pagoda' is large (e.g. 30 cm tall) with hundreds of orange-red flowers and buds.
- (b) *Jasminum humile*, Jasmine. (S. samanpichcha) A favourite scented flower growing on a straggling climber.
- (c) *Jasminum sambac*, Jasmine, (S. getapichcha) A favourite shrub because of its scented flowers.

---

\* MS received in April 1982  
Miss Chandanie Atapattu, 17 years, Hillwood College, Kandy... Miss Sithy Shafiya Cuncheer, 17 years, Hillwood College, Kandy, Miss Anula Kumari Ilukkumbura, 17 years, Hillwood College, Kandy.

**Method. A. Time of day at which the flower opens.**

A number of mature buds were marked by tying their stalks lightly with a thread. They were then observed at intervals of 10-60 minutes to see whether they had opened, 'open' meant that the petals and stamens were fully expanded. The number of flowers observed was about 50 at a time for the pagoda flower and 20-25 for the jasmines. The observations were made in July-August 1981.

**B. Duration for which the flowers stay open.**

The flowers, marked as described above, but with numbered pieces of card attached to the thread in the case of the pagoda flower, were observed periodically to see whether they had faded, got detached or fallen. For the pagoda flower, 50 flowers were observed at half-hourly intervals during the morning and at 3-hourly intervals during the afternoon. (July 1981). For Jasmine (*J. humile*), five flowers were observed (on 25-27 June 1981), and for *J. sambac*, seven flowers (on 1-2 August '81).

**Results and conclusions**

**A. Time of day at which the flowers open.**

**1. Pagoda, flower, Figure 1 shows that :**

- (a) the flowers open between 5 a.m. and 8.30 a.m.
- (b) the curve for the relationship between time of day and number of opened flowers is S-shaped, the steep part of the S being at 6-6.30 a.m.
- (c) the curve varies in detail from day to day.

**2. *Jasminum humile* (S. samanpichcha) Figure 2 shows S-shaped curves for this jasmine flower.**

As in figure 1 for the pagoda flower but the curves are broader and less steep, and the variability from day to day is greater.

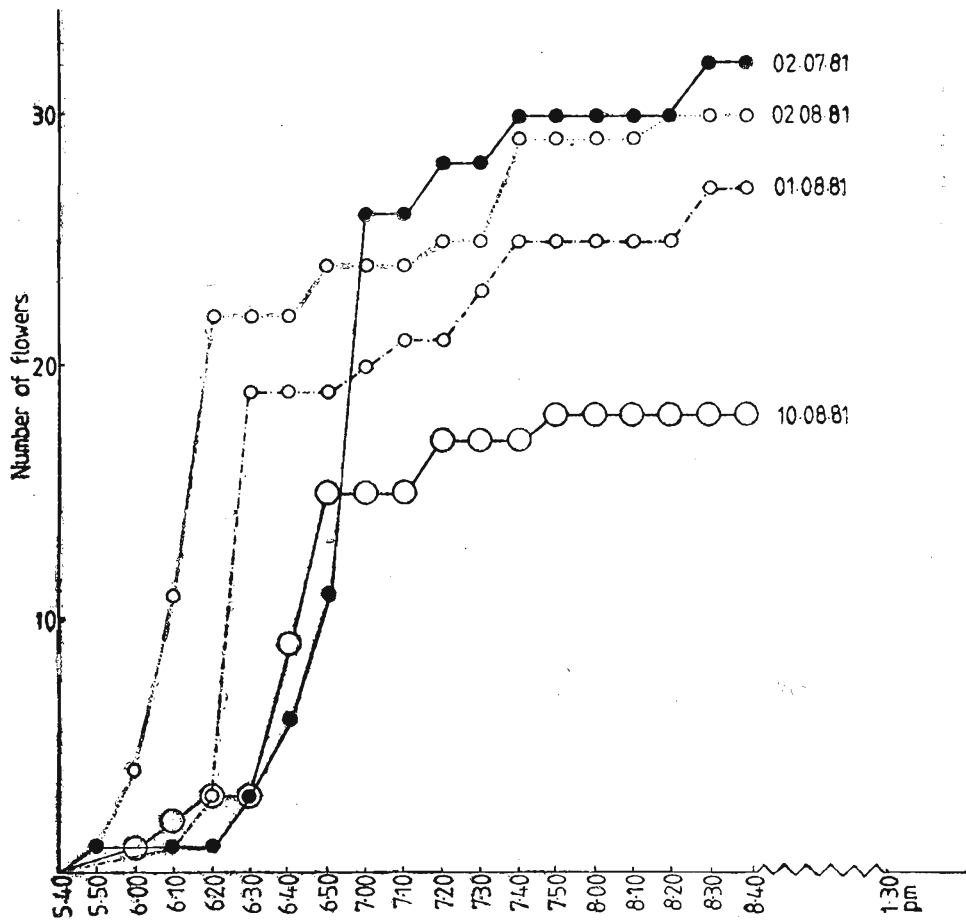

Figure 1 Time of day at which the pagoda flowers open

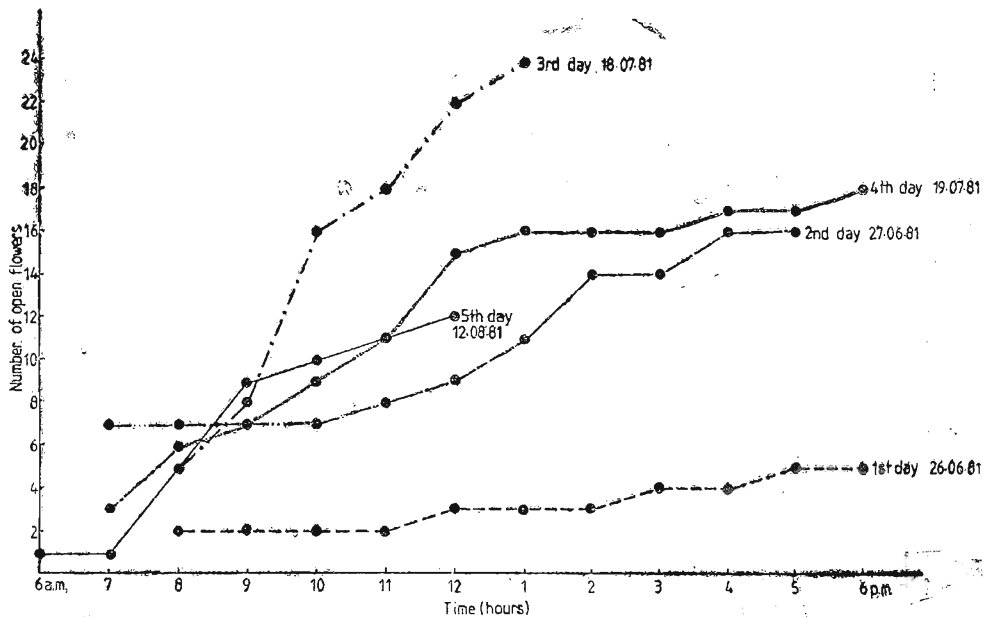

Figure 2. Time of day at which the flowers of *Jasminum humile* open

3. *J. sambac* (*S. getapichcha*). figure 3

The curve is similar to that for the pagoda flower, with the steep part at 6-7 a.m.

B. Duration for which the flower is open

1. Pagoda, flower, figure 4 shows the results

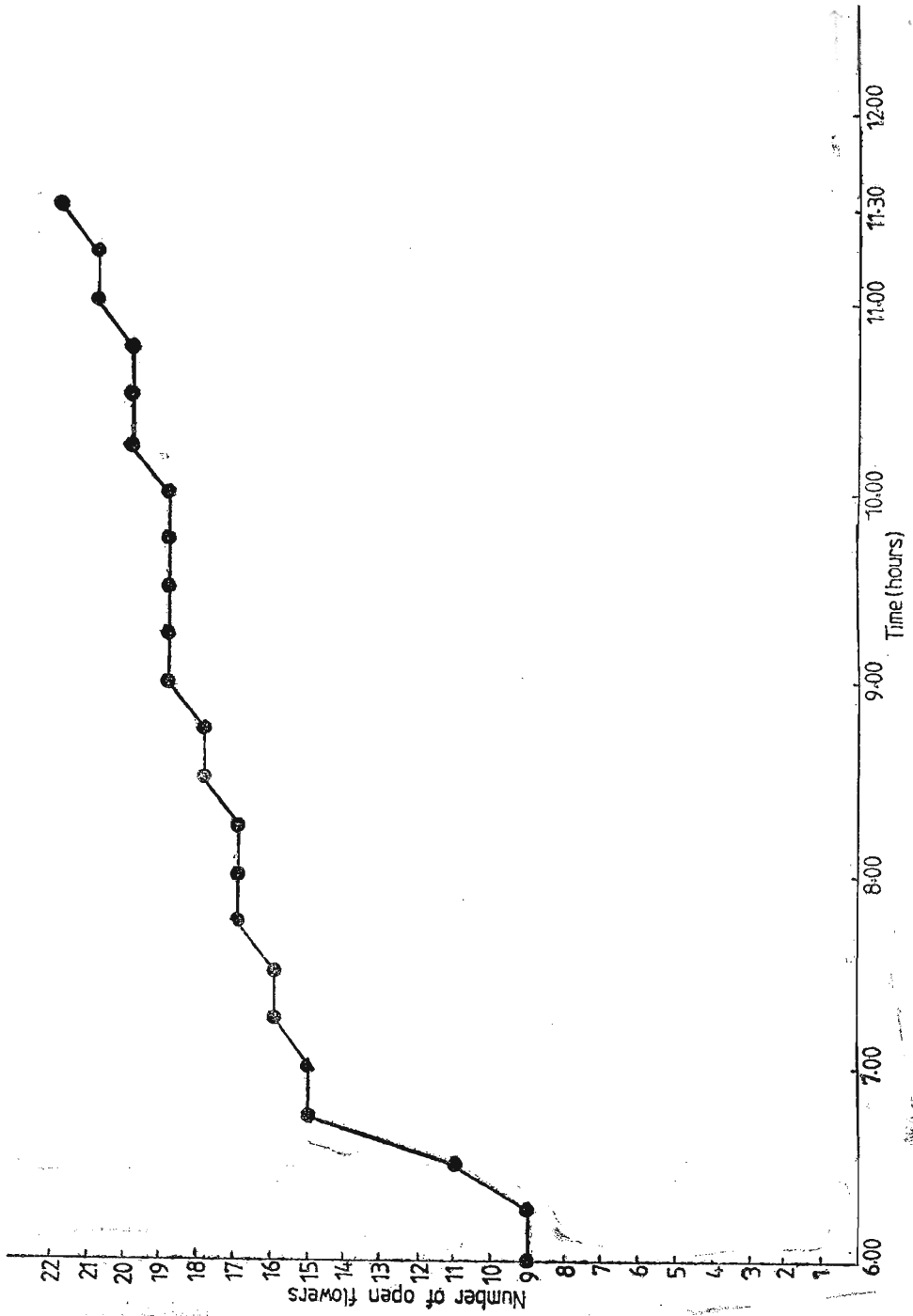

Figure 3 Time of day at which the flowers of Jasminum sambac open.

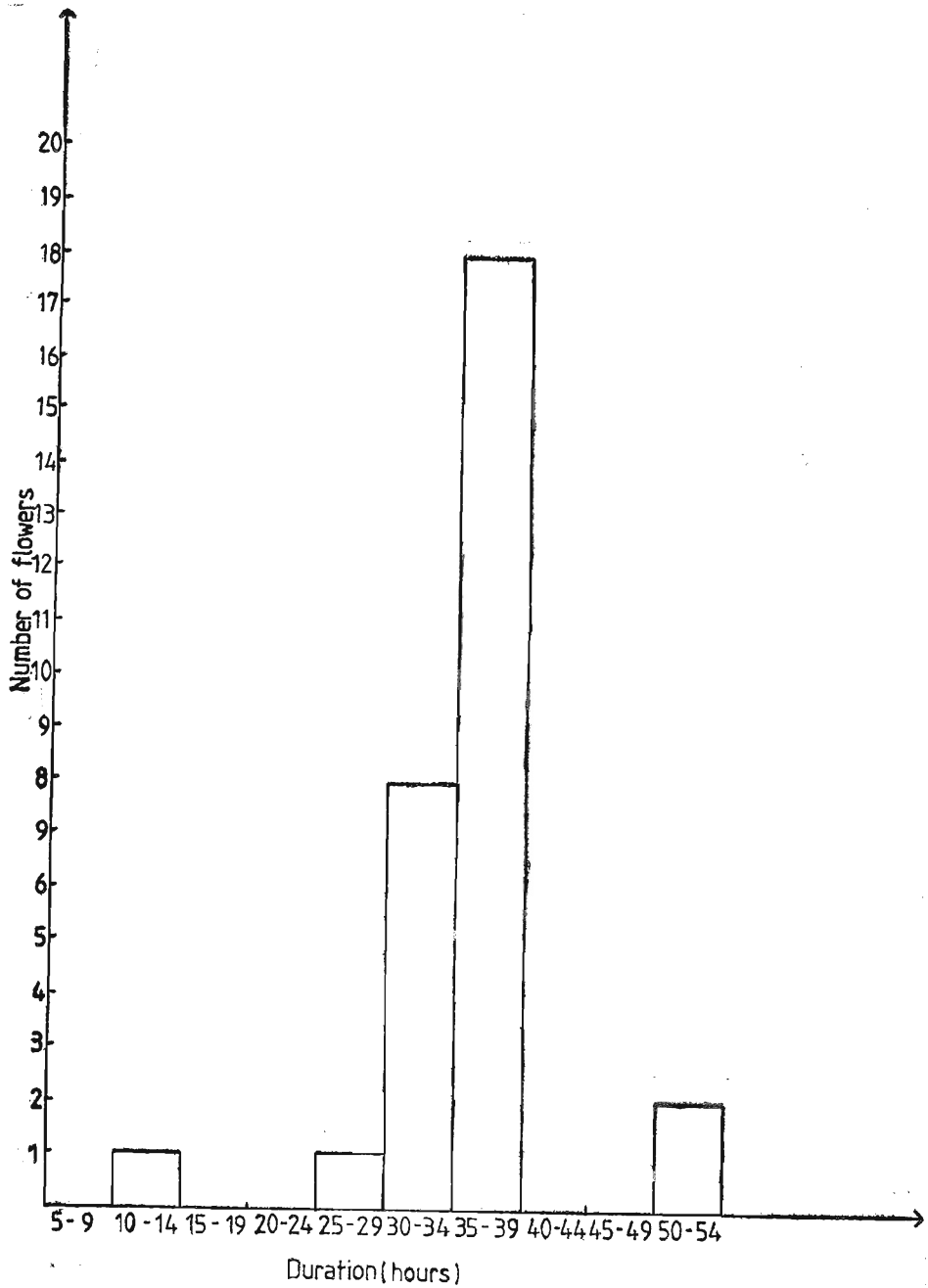

Figure 4. Frequency distribution of the duration, for which the pagoda flower was open.

in the form of a frequency distribution. The mean and mode are at 35-39 hours.

## 2. *Jasminum humile*, Table 1

Table 1. Duration of life of the flower of *Jasminum humile*. 5 flowers observed from opening of the flower to its falling off.

Duration from start of observation at 6 a.m. on 25.6.81 (hours)	Number of flowers	
	Open	Fallen off
0	0	—
12	5	0
24	5	0
36	3	2
48	0	5

The duration is about 32 hours.

3. *J. sambac*, figure 5 shows the results for each of 7 flowers. The duration is about 24 hours.

### Discussion :

All three flowers examined in the present study showed an S-shaped cumulative frequency distribution for the time of day at which the flower opens. This is another way of saying that the frequency distributions were apparently 'normal' i.e. "bell shaped". The steep part of the S curve, or the peak of the 'bell', was in the morning, especially at 6-7 a.m in the case of the pagoda flower and *Jasminum sambac* (*S. getapichcha*). A broad S in the cumulative frequency distribution would correspond with a wide bell in the frequency distribution curve, i.e. the variability is large.

The above pattern of frequency distribution is found in the case of the time of opening of other flowers too. e.g. *Elephantopus scaber* (Eriyagama, 1971). It is also found in a wide range of biological phenomena of development and growth, e.g. menarche (Dissanayake, 1970), growth of the human body length (Tanner, 1977).

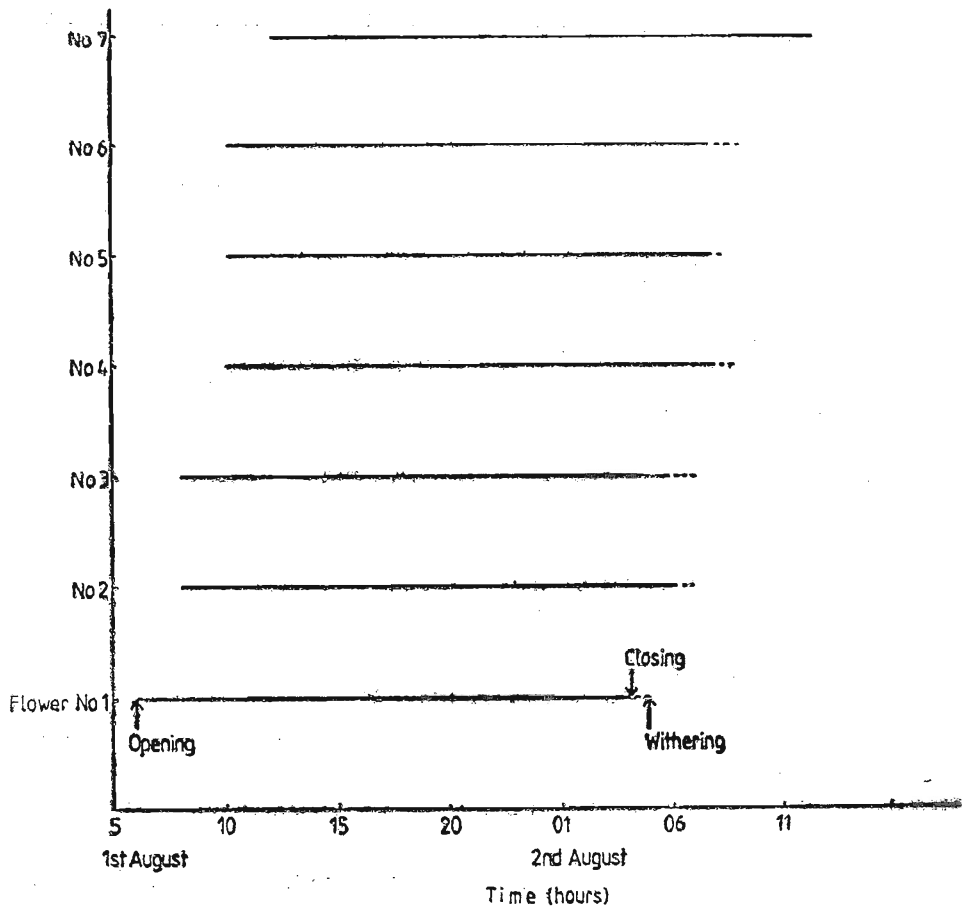

Figure 5. Duration of life of seven flowers of *Jasminum sambac*.

Many biological phenomena show a daily rhythm (Buenning, 1973.) The periodic opening of flowers and their periodic closing is one of them (Meyer *et al*, 1965). Another example of daily rhythm is found in shoot growth (increased in daytime in some plants, night time in others).

The particular pattern of the daily rhythm for any given plant is probably of internal origin in the plant. Each species of flower has its own rhythm. It is also known that when a plant blossoms, further flowering on the plant is inhibited, owing to internal changes in the plant.

External factors can affect the rhythm. They include light (flowering is less in the shade), temperature (flowering is less in the cold). Casual observation gave us the impression that the incidence of flower opening in rainy weather, as compared with that for dry weather, was greater for the pagoda flower, but less for the jasmine (*J. humile*). The time of opening of *J. sambac* appeared to be earlier on a rainy day.

*Summary.* The pagoda flower (*Clerodendron paniculatum* S. pinna) was found to open mostly at 6-7 a. m. and to last 35-39 hours. The corresponding figures for *Jasminum humile* (jasmine, S. samanpichcha) were 6-7 a.m. and 32 hours. The flower of *Jasminum sambac* (jasmine, S. getapichcha) opened over a wider period of time stretching over morning and afternoon and it lasted about 24 hours.

#### References

- Buenning, E. *The physiological clock: circadian rhythms and biological chronometry.* Berlin; Springer, 3rd ed. 1973.
- Dissanayake, P. Age of menarche in school girls in Kandy, Ceylon. *Proceedings of the Third Biennial Conference of the Asian Association for Biology Education, 1970.* AABE Secretariat, Science Education Centre, University of the Philippines. pp 37-40.
- Eriyagama, I. Some observations on the flowering pattern of *Elephantopus scaber*. *School biology investigations* (volume 1), p. 3-8. CAAS School Biology Project, 1971.
- Meyer, E. S., Anderson, D. B. and Bohning, R. H. *Introduction to plant physiology.* New Delhi: Van Nostrand/East-West Press. 1965.
- Tanner, J. M. The human growth curve. ch. 19 in *Human biology*, by Harrison, G. A., Weiner J. S., Tanner, J. M. and Barnicot, N. A. Oxford: Oxford University Press. 2nd ed. 1977.

# FIREFLY LIGHT AND THE WEATHER

D. D. Dias\*

## Introduction

Fireflies were seen to be abundant on some nights and few on other nights, as judged by their flashing light. Could this difference be due to the weather ?

## Method

An estimate was made of the number of flashing fireflies present on a tree and in the grass near the ground just outside a house in Nawayalatenne, Katugastota. It was a quick rough estimate. This was done at 19h (7 p.m.) 20h and 21h each night for 32 successive nights on 25.5.79 — 26.6.79, and again for 37 nights on 5.10.79 — 11.11.79. A note was made on each occasion of the weather at that time, using five common terms, namely, 1. rain & wind, 2. dry, 3. ordinary, 4. windy, 5. some rainfall. When the number of fireflies seen was very large, no attempt was made to count them; the count was recorded as being “over 20 fireflies”.

Results are shown in table I & II

Table 1. Weather and firefly light in trees and in grass during the period 25-5-79-26.6.79 (32 days).

Weather	Average number of flashing fireflies					
	Trees			Grass		
	At 19h	20h	21h	At 19h	20h	21h
Rain + wind ..	1.0	—	4.0	0	—	0
Dry ..	15.8	12.9	6.5	0.5	0.6	0.3
Ordinary ..	13.4	17.4	15.5	0	1.0	0.9
Some rain ..	7.7	8.5	8.0	0	1.5	0
Wind only ..	6.3	12.0	4.0	0	0	1.0

\* MS received in March 1980.  
Miss Dharma Deepa Dias, 20 years, Girls' High School, Kandy. Miss Dias is now a student in Agriculture, University of Peradeniya.

Table II. Weather firefly light in trees and in grass during the period 5.10.79 - 11.11.79 (37 days).

Weather	Average number of flashing fireflies					
	Trees			Grass		
	At 19h	20h	21h	At 19h	20h	21h
Rain + wind ..	11.2	12.0	1.0	0.2	0	0
Dry ..	16.9	13.5	10.2	2.5	1.5	0.4
Ordinary ..	15.5	13.3	7.2	1.8	0.8	0.3
Some rain ..	18.3	13.4	10.5	1.4	0.3	0
Wind only ..	—	—	—	—	—	—

### Conclusions

1. There were more fireflies at 19 & 20h than at 21h, and more in the trees than in the grass.
2. On days with rain & wind, the number of fireflies was less.
3. On dry or ordinary days the number of fireflies was largest.

### Discussion

A number of difficulties were met with in the course of this 'field' study. The estimate of the size of the firefly population on the tree or in the grass was very rough indeed, principally because each firefly flashed rhythmically a number of times for just a few seconds and it then became invisible. On some nights the numbers of fireflies were very large, so that they could not all be counted.

The reasons why more fireflies are seen at 19h than at 21h, or more on plain days than on rainy or windy days, remain to be found. A classic treatise on bioluminescence (1) shed no light on these smaller matters.

### Reference

1. Harvey, E. N. *Living light*. Princeton University Press 1940.

# RELATIONSHIP BETWEEN DISTANCE AND TIME IN ATHLETIC SPRINTING

D. D. Dias & A. Weerasinghe\*

## Introduction

The time taken to run a long race seems to be disproportionately greater than that for a short race. Thus a 100 metre race is run in, say 12 seconds, but an 800 m race takes, say, 130 seconds and not 96 seconds. A graph showing the relationship between race length and duration would therefore look like an ascending curve. But if the graph be drawn with the *logarithmic* values of race length and duration a straight line relationship is displayed. This has been shown for world athletic records in sprinting (Lloyd, 1966). We looked for a similar relationship in the data for Lankan athletic records.

## Method

Data on Lankan sprinting records were obtained from current newspaper cuttings. The international data were taken from a sports encyclopaedia. We were not successful in getting the data from two professional sports experts whom we approached. The durations refer to record-breaking events, i.e. the shortest times in which the race was run.

Results are shown in tables 1 & 2 and figures 1 & 2.

Table 1. Distance and record time to run races

Distance (meters)	Record time (seconds)		
	National (Lankan)		International
	Males	Females	Males
100	10.5	12.2	9.705
200	21.7	25.6	20.95
400	47.3	58.6	44.67
800	113.0	147.1	97.95
1500	237.0	307.6	196.1
5000	866.0	—	746.3
10000	1845	—	1611.0

\* MS received in July 1981.

Miss Dharma Deepa Dias, 21 years, student, Girls' High School, Kandy.

Miss Anoja Weerasinghe, 21 years, student, Girls' High School, Kandy.

Miss Dias & Miss Weerasinghe are at present students in the Faculty of Agriculture, University of Peradeniya.

Table 2. Log distance and log time to run races

Logarithm of distance (log m)	Logarithm of time (log s)		
	National (Lankan)		International
	Males	Females	Males
2.0000	1.0212	1.0864	0.9870
2.3010	1.3365	1.4082	1.3211
2.6021	1.6749	1.7679	1.65
2.9031	2.0531	2.1676	1.991
3.1761	2.3747	2.4880	2.2925
3.6990	2.9375	—	2.8729
4.0000	3.2660	—	3.207

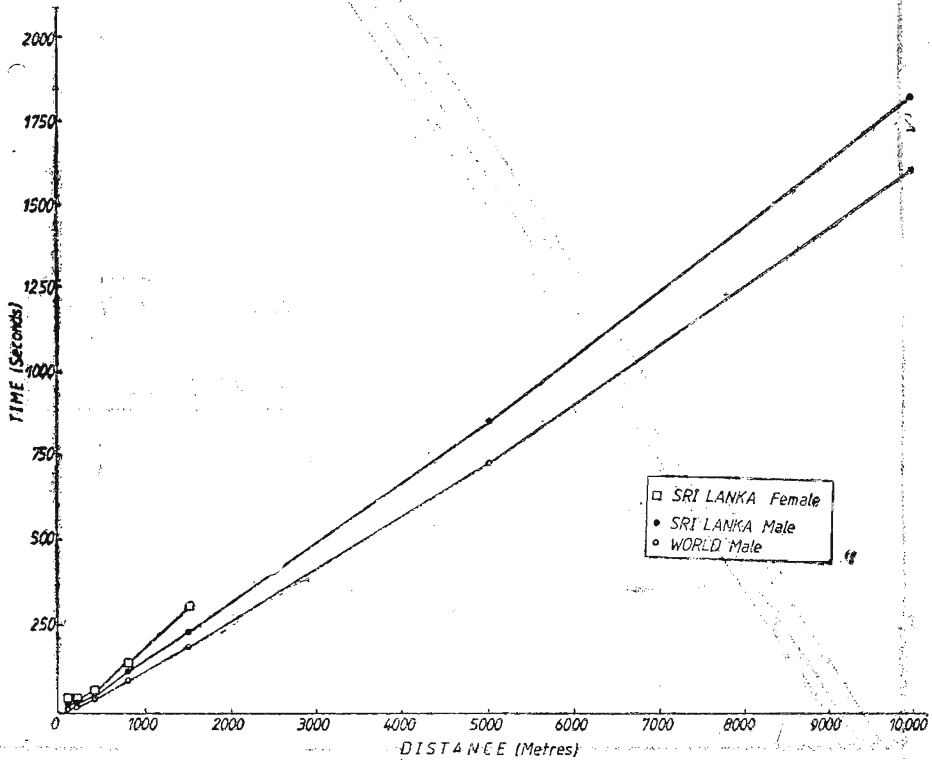

Figure 1. Time taken to run various distances by Sri Lankan & international champions.

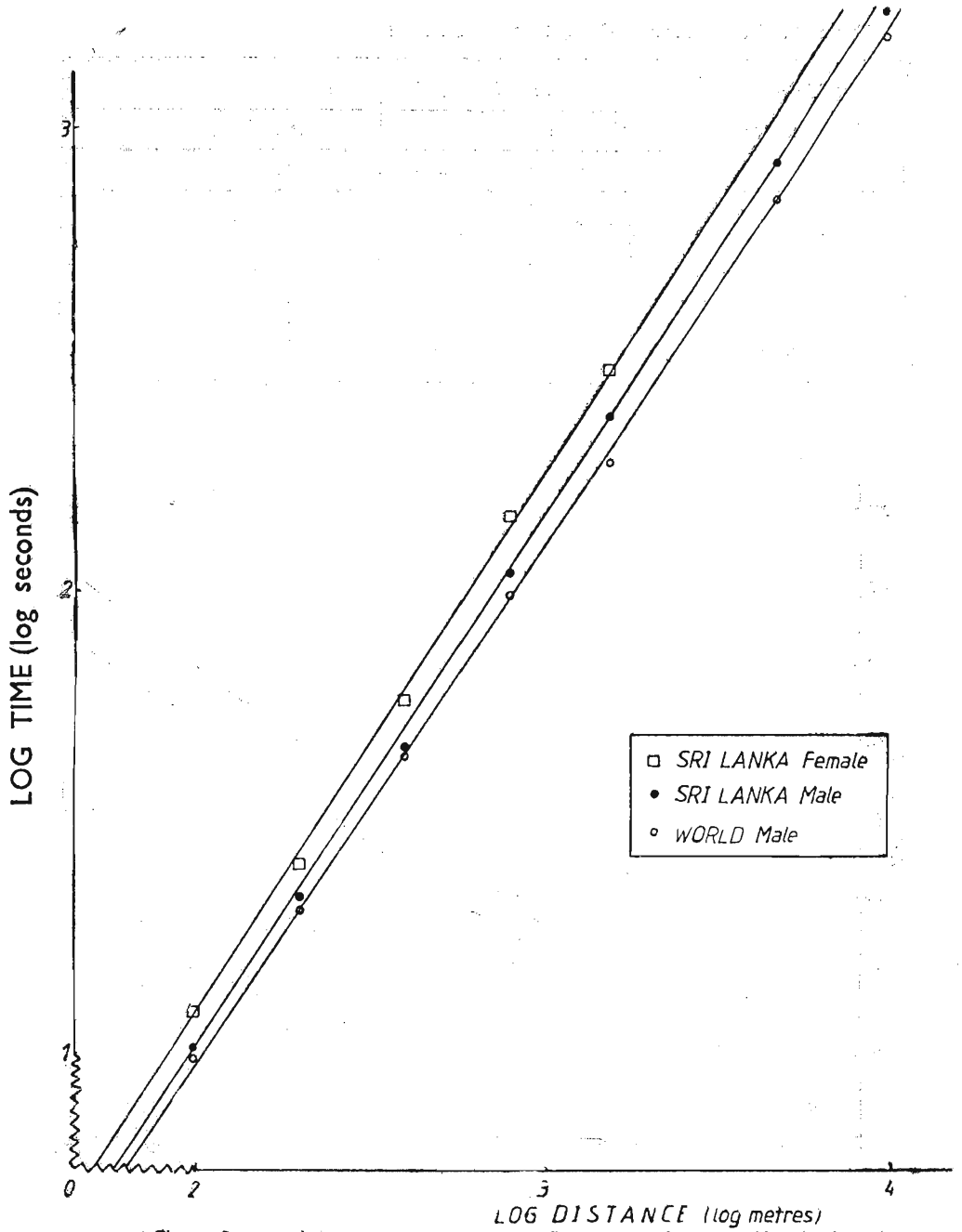

Figure 2 Log distance vs log time for Sri Lankan & international champions

## Conclusions

The relationship between distance and time for sprinting athletic records is well summarized as :—

$$\log y = m \log x + c$$

Where y is the time in seconds.

x is the distance in metres

m is the slope of the straight line graph, in log seconds per log metre

c is the intercept on the y axis, in seconds.

For international record-breaking male sprinters,

$$\log y = 1.1053 \log x - 1.2186$$

For Lankan record-breaking male sprinters,

$$\log y = 1.1228 \log x - 1.2298$$

For Lankan record-breaking female sprinters,

$$\log y = 1.1591 \log x - 1.2193$$

## Discussion

The rule that there is a linear relationship between log distance and log time in sprinting records is seen to be applicable to Lankan athletes too. The graph for Lankan male sprinters, however, is situated at a higher level than that for world class male sprinters; that is, Lankan sprinters take longer than world-class sprinters to run the same distance. The causes of this inferiority are uncertain. Factors which should be taken into account would probably include selection procedures for athletes, physique, physical training, and nutrition. The graph for Lankan female sprinters lies at an even higher level than for the males, but this is to be expected on the basis of the generally-accepted finding that females have a smaller physique and physical fitness than do males.

## Summary

There is a linear relationship between the logarithmic values for distance run and for the time taken by record-breaking athletes to run the race. The Lankan values are different from those for international athletes.

For Lankan males, log time in seconds = 1.228 X log distance  
in metres — 1.2298

## Acknowledgements

We thank Prof. V. Basanayake who suggested this problem to us.

## Reference

1. Lloyd, B. B. The energetics of running : an analysis of world records. *Advancement of Science*, 1966 January, pp. 515 - 530.

# SPIRALS OF THE TENDRIL OF ORANGE BIGNONIA

A. Dissanayake\*

## Introduction

The orange bignonia, which is grown in gardens, is a tendril climber. A pair of tendrils arises at each node on the stem, one tendril on each side of the node. Each tendril has two spirals. The direction of each spiral is clockwise or anti-clockwise. It is commonly stated that, in a given tendril, one spiral is clockwise and the other anti-clockwise. I wished to verify this for the orange bignonia creeper. In an earlier study the number of spirals in the tendrils of the bitter gourd were found to vary from 1 to 7, and in the passion fruit from 2 to 5, and each spiral had an average of about 7-9 turns but the direction of the spirals was not recorded (Dissanayake, 1981).

## Method

50 pairs of tendrils were examined on a single plant. Each tendril had two spirals. The direction of each spiral was recorded as clockwise or anti-clockwise.

## Results

Tendrils with one spiral clockwise and the other anti-clockwise, 38

Tendrils with both spirals clockwise or anti-clockwise, 12

The difference is statistically significant ( $p < .01\%$  by the 50% Probability Test, as described in Langley, 1970).

## Conclusion

76% of the tendrils of the orange bignonia have spirals which are coiled in opposite directions; 38% have spirals which are coiled in the same direction.

## Summary

In 50 pairs of tendrils, the spiral turns of the two tendrils of each pair were found to be opposite in direction in 38 pairs, and in the same direction in 12. The difference is statistically significant.

## References

Dissanayake, A. Number of sections and turns in the tendrils of the bitter gourd and passion fruit creeper. *Science investigations* no. 1 (June 1981), pp 7-8.

Langley R. *Practical statistics*. London: Pan Books. 1968 (1970 reprint).

\* Miss Ajitha Dissanayake, 19½ years  
MS received on 16.7. 1980.

# PLEASANT/UNPLEASANT RESPONSE TO THE ODOUR OF LANTANA FLOWERS, GUAVA LEAVES AND MADURUTHALA BASIL LEAVES

A. Dissanayake\*

## Introduction

The Sinhalese name for Lantana, 'gandapana', at first sight seems to suggest a nasty odour ('ganda'). The plant, however, has a strong odour which is pleasant to many persons. The present survey was done to estimate the proportion of persons who find it pleasant or unpleasant.

## Method

The material to be smelt, Lantana flowers or guava leaves of maduruthala (*Ocimum sanctum*) leaves was put into a paper bag. The paper was opaque so that the material was invisible, but the odour from the leaves was easily detectable on bringing the bag towards the nose. The subjects were requested to smell the bag and to state whether the odour was pleasant, neutral or unpleasant, and also whether they could identify the material from the odour. The age range of the subjects was 11 to 23 years.

Results are shown in Table 1.

Table 1. Odour of Lantana flowers, guava leaves and maduruthala leaves. Number (and percent) of subjects reporting that the odour was pleasant, neutral or unpleasant. F females, M, males.

	<i>Lantana</i>			<i>Guava</i>			<i>Maduruthala</i>		
	<i>F</i>	<i>M</i>	<i>Both</i>	<i>F</i>	<i>M</i>	<i>Both</i>	<i>F</i>	<i>M</i>	<i>Both</i>
Number of persons	65	17	83	48	8	56	52	10	62
Response :- Pleasant odour	50 (75.8)	12 (70.5)	62	35 (72.91)	7 (87.5)	42	44 (84.61)	8 (80.0)	52
Unpleasant odour	10 (15.3)	4 (23.5)	14	11 (22.91)	1 (12.5)	12	6 (11.53)	2 (20.0)	8
Neither pleasant nor unpleasant	5 (7.6)	1 (5.8)	6	2 (4.16)	—	2	1 (1.92)	—	1
Simultaneously pleasant & unpleasant	—	—	—	—	—	—	1 (1.92)	—	1

\* Miss Ajitha Dissanayake, 20 years.

Difference between the responses to the three plant materials, Cochran's test, Chi square 1.72, degrees of freedom 2, not significant.

Association between dislike of the odour of Lantana and dislike of the odour of maduruthala. Chi square 0.84, degrees of freedom 1, not significant

### Conclusions

1. The majority of persons (about two-thirds of the total number) report that the odour of the materials was pleasant. This was so for each of the three materials.

2. A minority found the odour unpleasant, and a still smaller proportion of persons found the odour to be neutral.

3. There was no sex difference in the responses.

4. There was no association between dislike of the odour of Lantana and dislike of the odour of maduruthala.

### Discussion

A scent may attract some persons and be neutral or even repulsive to others. In a study on verbena flowers (Blakeslee, 1918), two kinds of verbena, pale-pink and red, were used. Of 26 male subjects, 17 preferred the pale pink and 9 the red. Of 13 women, 9 preferred the pale-pink and 4 the red. Spikenard, mentioned in the Bible as a perfume, is said to be valued in the East and despised in the west (Moncrieff, 1967). In the present study we found that three selected odoriferous materials-lantana flowers, guava leaves and maduruthala leaves were attractive in odour to about 75% of a group of persons, repulsive to about 20%, and neutral to about 5%. Incidentally, lantana belongs to the same family as verbena (Verbenaceae). The physical basis of the interpersonal differences in response to scents is unknown.

### Acknowledgements

I thank Prof. V. Basnayake for suggesting the problem to me and for advice and assistance with the statistical calculations.

### References

- Blakeslee, A. F. Unlike reactions of different individuals to fragrance in verbena flower. *Science*, 1918, 48, 288.
- Moncrieff, R. W. *The chemical senses*. London: Leonard Hill, 3ed. 1967. p. 172.

# VARIATION IN THE NUMBER OF PETALS OF FLOWERS

G. Ekanayake\*

## Introduction

I wished to count the number of petals in various flowers which were available in the vicinity of my home. During this counting I became aware that the number of petals could vary even in the same species of plant, and that the variability seemed to increase with the number of petals in the typical flower of the species.

## Method

The number of petals in a flower was counted and recorded. In flowers which had a large number of petals the counting was done from below upwards, each counted petal being removed before counting the next petal. Only fresh flowers were used, as old flowers tend to lose their petals. A hand lens was used to count the petals in small flowers.

Results are shown in Table 1.

Table 1. Relationship between the average number of petals in a flower and the variability in the number of petals.

Flower	Number of petals	
	Average	Range
Coconut	3	—
Rathmal (Ixora), asoka	4	—
Flamboyante, pumpkin, shoeflower, papaw, chilli, watusudda, abutilon, dambala, kalukamberiya, pettan, araliya, kaduru, damson, bougainvillea, clerodendron,	5	—
kiribadu (Ipomoea), Thunbergia grandiflora, guava, jamfruit, bean, maekaral, waetahiriya	6	—
An orchid, sepalika, a lily, undupiyali	7	—
Jasmine (two kinds)	8	—
Daaspathiya (small), daaspathiya (larger)*	9	—
Ground orchid	14	—
Nakkasuriya	19.3	17 — 23
Rose	26	23 — 29
Zinnia (small)*	35.3	32 — 40
Shoeflower variety	45.3	40 — 51
Rose variety	52	47 — 58
Dahlia*	53	49 — 58
Daaspathiya (large)*	74.3	70 — 75
Zinnia (large)*	146.7	140 — 153
Barbeton*		

\* The 'petals' in these flowers are the petal-like bracts.

\* Ganesh Ekanayake, 15 years, Grade 9, Dharmarajah College, Kandy. MS received on 2.2.82.

## Conclusions

Flowers with up to 14 petals showed no variability at all in the number of petals per flower. Flowers which had a larger number of petals showed variability in the number of petals per flower, and this variability increased as the average number of petals per flower increased.

## Discussion

The average number of petals in the flowers with large numbers of petals is not a fixed number; as with any other average, the absolute value will change with each series of counts. It is therefore only an indicator of what is the typical number of petals for a many-petalled flower. Likewise the ranges observed by me for the number of petals in many-petalled flowers are likely to change if very large numbers of such flowers are counted.

A flower such as the nakkasuriya, with 14 petals per flower; seems to be the watershed between little or no variability (for flowers with fewer than 14 petals) and increasing amounts of variability (for flowers with more than 14 petals). I did see some nakkasuriya flowers with less than 14 petals; in all these cases, the missing petals were marked by the presence of gaps in the array of petals.

## Summary

The number of petals in a flower of a given species showed no variability when the number was 14 or less. When the number was more than 14 per flower, there was variability in the number of petals per flower, and the variability increased with the number of petals.

## Acknowledgements

I thank my teachers, Mrs. Gooneratne and Mrs. Warakagoda who directed me to do this project; my mother, who obtained flowers for me and helped me with their names; and Professor Basnayake for guidance.

## References

- Gilmour, J. & Walters, M. *Wild flowers*. London : Collins. 1954.
- Pulimood, S. G. & Joshua, A. *A textbook of botany*. Colombo : Lake House . 1948.
- Rendle, A. B. *The classification of flowering plants*. Cambridge University Press. 1959.

# CRACKING SOUND ON PULLING OR PRESSING ON THE FINGERS

S. Fernando\*

## Introduction

When the fingers are pulled or pressed upon, a cracking sound is frequently produced. The sound comes usually from the knuckle joint (metacarpophalangeal joint) or the adjacent finger joint (first interphalangeal joint). I sought to find out how common this phenomenon is.

## Method

The subjects were 10 males and 20 females aged about 16-21 years. Each subject was asked to try to produce the cracking sound by pulling or pressing on each finger of his/her own hands. This was done in my presence at about 9.30 - 10 am. The survey was done on 10 successive days. Each subject was tested only once.

Results are shown in Tables I and II .

Table 1. Cracking sound produced by pulling or pressing on the fingers

Sex	Number	Side	Number (and per cent) of fingers from which sound was elicited*				
			Finger no. I (thumb)	II (index)	III (middle)	IV (ring)	V (little)
Male	10	Left	6(60)	9(90)	9(90)	9(90)	7(70)
		Right	9(90)	9(90)	10(100)	10(100)	8(80)
Female	20	Left	6(30)	17(85)	12(60)	13(65)	12(60)
		Right	11(55)	16(80)	17(85)	14(70)	11(55)

\* From the knuckle joint or the proximal interphalangeal joint or both.

\* Miss Shereen Fernando, 22 years.  
57, Kandos Road, Kundasale.

Table II. Cracking sound elicited from both the knuckle joint and the adjacent first interphalangeal joint

Sex	Number	Side	Number (and per cent) of fingers from which sound was elicited from both joints				
			Finger no. I	II	III	IV	V
Male	10	Left	6(60)	1(10)	2(20)	1(10)	2(20)
		Right	7(70)	2(20)	3(30)	2(20)	5(50)
Female	20	Left	1(5)	1(5)	2(10)	0(0)	2(10)
		Right	0(0)	1(5)	2(10)	1(5)	0(0)

### Conclusions.

1. Males showed a higher incidence of production of the joint cracking sound.
2. The second, third and fourth fingers (index, middle and ring fingers) gave an incidence of 80%, which is higher than that of the first and fifth (thumb and little finger), 58%.
3. The fingers of the right hand gave a higher incidence than those of the left.
4. A double sound, i. e. sound could be obtained from both the knuckle joint and the proximal interphalangeal joint of the same finger, rather frequently in males, especially from the thumb and little finger. Females showed a low incidence of the double sound.

### Discussion

The cracking sound produced by pulling or pressing on the finger joints is hardly mentioned in textbooks of anatomy or physiology or even in textbooks on joints. Perhaps it is so familiar an experience that it does not need mention.

The findings described in the present paper, showing that the finger joints of males crack more than those of females, and the mid fingers crack more than the thumb or little finger, and the right hand more than the left, are not easy to explain. The general explanation for the cracking sound is believed to be the sudden entry of gases to fill the vacuum which is created when the joint is opened up by pulling or pressing the bones apart.

## Summary

The incidence of the cracking sound produced by pulling or pressing on the finger joints was estimated in a group of 10 males and 20 females. Males showed a higher incidence than did the females, the right hand more than the left, and the middle group of fingers more than the thumb or little finger.

## LEAF VEINS AND LEAF SIZE

P. B. Gunaratne\*

### Introduction

One might suppose that the number of veins should increase with the size of the leaf. To test this supposition I looked for the relationship between these two variables in a number of plants.

### Method

15 species of plants were examined. The number of large veins which branched off to left and right from the midrib was counted and recorded as 'the number of veins' in the leaf. This was done in 5 leaves taken from the middle region of the leafy zone of the plant. The size of the leaf was measured as the length and the breadth of a leaf which had a typical (modal) number of veins for its species.

Results are shown in Table 1.

Table I. Number of veins per leaf and size of leaf.

Species	Number of veins in 5 leaves	No. of veins	Representative figure for leaf size	
			Length (cm)	Breadth (cm)
Balsam	10, 9, 9, 8, 9	9	4.1	2.6
Shoeflower	8, 9, 10, 9, 9	9	5.6	3.4
Anoda	22, 17, 21, 19	15	9.4	3.6
Kothala	10, 8, 11, 12, 9	10	7.7	2.2
Rose	15, 13, 14, 13, 12	13	5.1	3.1
Kadupahara	12, 8, 8, 12, 8	9	6.8	1.9
Rata ambilla	13, 13, 11, 9, 12	11	5.4	4.1
Rata nelli	20, 25, 24, 26, 24	23	8.4	3.5
Bougainvillea	13, 14, 11, 11, 14	12	6.4	4.4
Gatapichcha	11, 8, 9, 10, 8	9	4.7	3.8
Guava	28, 24, 38, 26, 27	28	10.7	1.4
Gandapana	17, 16, 14, 14, 17	13	6.5	3.8
Kapurarosa	8, 5, 5, 6, 7	6	4.9	1.7
Koodalu	19, 17, 20, 19, 17	18	5.1	2.3
Ginideeriya	6, 5, 7, 8, 6	6	4	2

\* P. B. Gunaratne, Student, Dharmaraja College, Kandy.  
MS received on 19.3.82.

## **Conclusion**

There is no relationship between the number of veins in the leaf and the size of the leaf.

## **Discussion**

What matters to the tissues of a leaf may well be the size of the network of tiny fine veins in the tissues. This fine network is fed by the large veins coming off the midrib. A very large vein may break up by a large number of divisions into the fine network in the tissues while a smaller vein may break up by fewer divisions into the same fine size of network. Thus it could be immaterial to the leaf whether the veins which branch off from the midrib are few and large or many and small. Further study is necessary to see whether this explanation is correct.

## **Summary**

There was no relationship between the number of veins in a leaf and the size of the leaf in 15 species of plants that were examined.

# GROWTH OF SUGAR CANE

L. B. Halangoda & U. G. Hanwella

## Introduction

We wished to find out whether the sugar cane stem grows equally at points along its length or whether growth takes place only at the top.

## Method

A 20 cm long piece of the upper end of a mature sugar cane stem was planted. Two new shoots emerged from buds in the planted piece of stem. One of the new shoots grew to a much greater extent than the other which broke. The new long shoot grew to a length of 13 cm in about 2 weeks. It was surmounted by a set of leaves. This new shoot was marked with chalk so that the marks were 1 cm apart. The 13 segments, each 1 cm long at the start of the observations, were measured with a piece of thread at weekly intervals in order to estimate the growth in length of each segment. This was done for 10 successive weeks. The total length of the new shoot at the end of the 10 weeks was 26.5 cm. The segments were numbered from 1 at the base of the shoot to 13 at the tip, for recording purposes.

## Results and conclusions

1. All of the 13 marked segments showed some growth more or less throughout the 10 weeks of observation. The overall average growth rate was 0.96 mm/week, the standard deviation was 0.988 mm/week. The greatest lengthening was in segment 13 (the tip of the shoot) followed by segment 1 (base of shoot).

2. The biggest growth rate was 5 mm/week, and this was in segment no. 10 which otherwise was not fast-growing.

3. The period of fastest growth (2 or 3 or more mm per week) was the first few weeks for segment 1, the middle weeks for segment 5, and the last few weeks for segment 13. The other segments showed no particular pattern.

---

\* L. B. Halangoda, 14 years, & U. S. Hanwella, 14 years, Students, Dharmaraja College Kandy.

MS received on 15.2.82.

# EARTHWORM'S CHOICE BETWEEN TURNING LEFT OR RIGHT

A. D. C. Jayatilleke\*

## Introduction

In Grade 6 we learnt about worms. The subject interested me and I wished to pursue it further. I chose to try to find out whether the earthworm, when faced with a choice between turning left or right, would show a preference one way or the other.

**Method.** I made a T-shaped wooden case (figure 1). It was placed on wet blotting paper in a darkened room. An earthworm was placed at the lower end of the vertical arm of the T. When the worm reached the horizontal arm of the T it could go left or right. The direction it actually took was noted down accordingly as left or right.

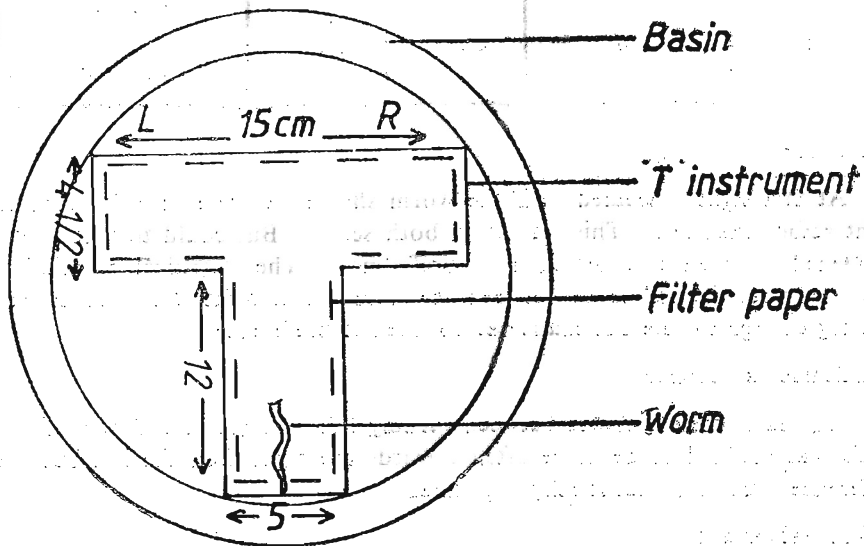

Figure 1. T-shaped maze

Received several years ago, not dated

\* A. D. Chandan Jayatilleka, (then 13 years of age)  
Trinity College, Kandy.

Two series of observations were made. In the first series the worm was observed in 50 successive passages along the T. The position of the T was constant. In the second series the worm was observed in 60 successive passages, the position of the T being changed at random.

The statistical significance of the difference between the number of left turns and the number of right turns was assessed from the standard error of the difference between two percentages (Garrett, 1967).

**Results.** Are shown in Table 1.

Table 1. Earthworm's choice between turning left or right

Series	Number of observations	Number (& percent) of times the worm turned		Significance of the difference between left & right
		to the left	to the right	
1	50	17(34%)	33(66%)	Not significant
2	60	24(40%)	36(60%)	Not significant

### Discussion

At first sight it seemed as if the worm showed a preference for turning right rather than left. This was so in both series. But could this not have happened by chance rather than by preference? The statistical calculation indicated that the difference between the numbers of right & left turns was not big enough to rule out chance as opposed to preference.

### Conclusion & summary

An earthworm's choice between turning left or right in a T-box in 110 trials was inclined to be more often towards the right than the left but the difference was not statistically significant.

### Acknowledgements

I thank Professor V. Basnayake for assistance with the statistical work.

### Reference

Garrett, H. E. *Statistics in psychology & education*. 4th Indian edition. Bombay : Vakil, Feffer & Simons. 1967.

# PREFERENCE FOR SHADE OR SUN

P. S. Kaluarachchi\*

## Introduction

When people have a choice of staying in the sun or shade, which do most of them prefer? This problem was suggested at a meeting of project work students. I undertook to make a simple preliminary study on the matter.

## Method

As soon as school is over in the early afternoon the pupils who travel by bus go to the bus stands. Some of these bus stands have shelters provided by the bus Company. A person has a choice of staying in the shelter or in the sun until the bus comes. The numbers of pupils in the sun and in the shade of the shelter at a bus stand near the school were counted on four days.

**Results.** Are shown in the table.

Table Number of pupils who stood in the shade or in the sun

Date	Time	Number of children in	
		the shade	the sun
81.1.22	1.30-1.45 p.m.	19	5
81.1.23	1.30-1.50 p.m.	15	2
81.1.26	1.30-1.45 p.m.	17	4
81.1.27	1.30-1.45 p.m.	14	6
	Average	16.3	4.3

## Conclusion

About 4 times as many children stayed in the shade as those who stayed in the sun.

\* Miss Priyanthi Shiyamala Kaluarachchi  
Grade 9, Girls' High School, Kandy.  
MS received in February 1981.

## Discussion

The commonsense notion that in the hot day time people mostly prefer to stay in the shade is borne out by the results. It needs further study to see whether those who chose to stand in the sun are the same persons day after day. That is, are there some few persons who regularly prefer the sun to the shade? If so, further questions would arise, e.g. why do they do so and how do they react to the heat?

## FOOD AND FEEDING IN A POND

M. Kathirgamarajah\*

### Introduction

There is a small pond at the Field Science Centre, Peradeniya Teacher Training College (figure 1).

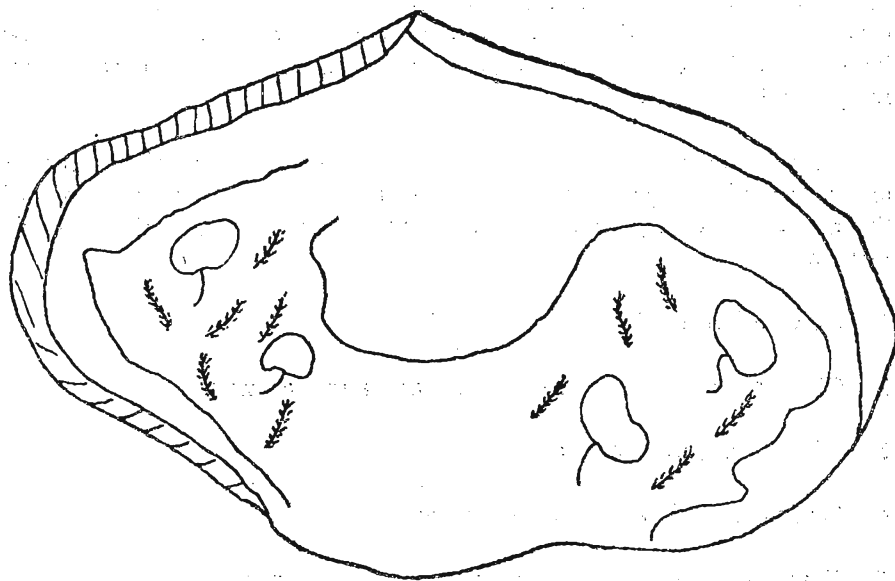

*Fig. 1. Diagram of the pond*

It has a maximum length of 8 ft 8 inches and a maximum breadth of 4 ft. It has a maximum depth of 10 inches. The pH of the water is 7, the temperature varied from 25°C – 29°C. depending on the time of the day. It has a number of organisms living in it.

---

MS received in January 1979.

\* Mrs. M. Kathirgamarajah, Mowbray College, Kandy.

## Purpose

To find out the feeding methods and food habits of the organisms and the possible inter relationships between the organisms with regard to their food habits.

## Materials and methods

First the pond was carefully observed and larger organisms identified. Now to identify some more of the organisms I collected samples of water which had small organisms in it. I also collected some mud which had living organisms. I observed the leaf surfaces carefully and washed one or two leaves into a dish to remove the organisms from the surface of the leaf. These samples I kept separately.

In the laboratory I observed drops of water from those samples under the microscope. I used binocular and fine microscopes to identify the animals. Feeding and food habits were studied using the following methods.

1. Observation of behaviour (outside)
2. Observation of gut contents (in transparent animals)
3. Dissection (dead animals)
4. Setting up of laboratory experiments
5. Examination of feeding mechanism (mouth parts)

Results. With the naked eye I was able to identify the following plants.

1. *Hydrilla*
2. Water lily
3. *Alternanthera sessilis*

Animals :—

1. Toads and tadpoles
2. Water snails
3. *Hydrometra species* (figure 2b)

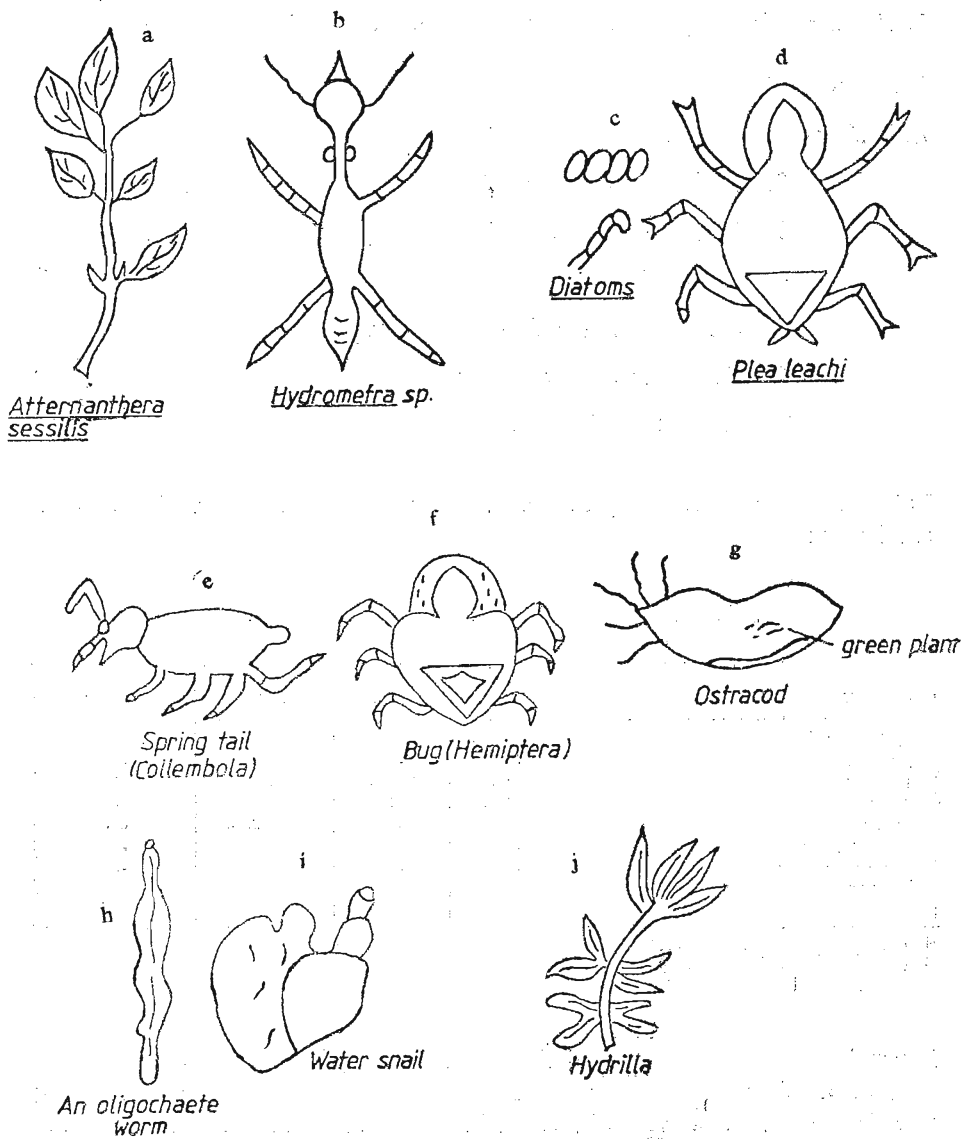

Fig 2 Organisms found in the pond

Under the microscope the following were identified.

Plant :- Diatoms. (figure 2c)

- Animals :-
1. *Plea leachi* (figure 2d)
  2. Spring tail (figure 2e)
  3. Bug (Hemipteran) (figure 2f)
  4. Ostracod (figure 2g)
  5. An Oligochaete (figure 2h) worm
  6. Water snail (gastropod)
  7. Tadpoles and frogs.

Table 1. shows the comparative number of organisms in the different sub-habitats

Table 1. Organisms in sub-habitats in the pond.

Species	Rocks	Plants	Mud	Stones
Arthropods	+	+	+	—
Annelids	—	—	+	—
Molluscs	+++	+++	+++	++
Amphibians	++	++	++	++
Hydrilla	—	—	+++	—
Water Lily	—	—	+	—
<i>Alternanthera sessilis</i>	—	—	+	—
Diatoms	+	+	+	+

+++ Common 50 or more

++ Medium 10 to 25

+ Rare, below 5

**Discussion and conclusions.** Of the organisms mentioned above *Hydrometra sp* had a piercing mouth part therefore it is a carnivore. The bug (Hemipteran) had a small insect inside its transparent alimentary canal, therefore it is a carnivore. The ostracod, a bivalved crustacean had green plants inside the body, therefore it is a herbivore.

The oligochaete worm had a transparent body with detritus, therefore this eats rotten plant substance.

The tadpoles were seen clinging to the *Hydrilla* plant with their mouth parts. The adult frogs were seen eating insects therefore they are carnivores. Observations and experiments showed that water lily leaf is eaten by water snails therefore the water snail is not a carnivore. The following chart gives a summary of the feeding habits.

<i>Animal species</i>	<i>Food habit</i>	<i>Evidence</i>
<i>Hydrometra</i> sp Bug (Hemipteran)	Carnivore Carnivore	Piercing mouth parts. piercing mouth parts, gut content (insect) Gut contents (green)
Ostracod (Crustacea) Oligochaete worm	Herbivore (Diatoms) Detritus eating	Gut contents (rotten plants).
Water snail	Herbivorous	Observation of behavior & lab expts
Tadpoles	Herbivorous	Observation of behavior
Frogs	Carnivore	Observation

**Acknowledgments.** I thank Professor Dowdeswell for guiding me to do this investigation and Professor V. Basnayake for guiding me to write this paper.

**References.**

Mendis, A.S. and Fernando, C. H. *A guide to the fresh water fauna of Ceylon.* Fisheries Research Station, Ceylon 1962.

## PARALYSIS OF ONE SIDE OF THE BODY IN A BIRD

S. R. B. Kotakadeniya\*

A house sparrow nest was found thrown down to the ground by crows. There were three nestlings whom I thereafter took charge of. They grew, but one of them had a short, weak, cold and bluish right leg. The right wing too was weak. This bird ate less and grew less than the others. It tended to get pecked by other birds when left in the open.

This case seems to show that birds can suffer from paralysis of one half of the body.

---

\* S. R. B. Kotakadeniya, 12 years  
Dharmaraja College, Kandy.  
Received 1982.1.27.

# WHITE SOIL OF WATTEGAMA : SUITABILITY FOR MAKING CHALK AND PIPE-CLAY

J. Palipane\*

**Introduction.** I came across an area of white soil in the Wattegama region at an elevation of 1575 feet above sea level. In the neighbourhood there were areas with white sand as well as areas with greenish or reddish soil.

On handling the soil I noticed that a powdery material adhered to my hands. This made me think of writing chalk which also leaves a deposit on the hands. I wondered whether writing chalk could be made from the white soil. Also, could pipe-clay, such is used for cleaning canvas shoes, be made from the soil?

## Method and results

### A. Writing chalk

A sample of the white soil was powdered. The powder was sieved through a mesh (125 holes per square inch) to get a fine dust. Water was added to the dust to get a doughy mixture. This was put into the cavity of a  $3\frac{1}{2}$  inch long piece of papaw leaf stalks which served as a mould. The material was found to set in about 24 hours. It was then removed from the mould and each piece looked like a piece of writing chalk.

It was dried in the sun for about 12 hours, which made it stronger. The chalk could be used for writing on a blackboard but it did not write very well on a shiny blackboard. The addition of colouring matter to the powder could produce coloured chalk.

**B. Pipe-clay.** The procedure was similar to the above but with the addition of a little 'blue' (washing blue) and a little gum to mixture. This was shaped by hand into a round block. The finished material seemed to be nearly as good as the commercial canvas shoe cleaner.

---

\* Jayampathy Palipane, 14 years, Grade 9A, Vidyarthi College, Kandy. (in 1973). MS received October 1973. Translated & edited by the editor.

When applied to a shoe it gave a brownish colour which however turned white on drying. The material could be used not only for making pipe-clay but also for making white objects such as masks by pouring it into suitable moulds.

**Discussion.** I did not succeed in finding out the name of the minerals in the white soil. I believed it is composed of oxides of aluminium and silicon, rather than of calcium - containing mineral.

I had previously made unsuccessful attempts to make writing chalk. In one such attempt I had tried to harden some material by pouring it into papaw stalks and then keeping these on a sheet of corrugated iron in the sun. I was trying to imitate the firing of clay in a kiln.

**Summary.** A white soil found in the Wattedgama region was successfully used to make pieces of writing chalk and canvas shoe cleaning material.

# PATTERN AND GROWTH OF THE TENDRILS OF THE PUMPKIN CREEPER

G. W. R. Weerasinghe\*

## Introduction.

A previous study on the tendrils of the passion fruit creeper and bitter gourd (Dissanayake, 1981) gave me the idea of studying the tendrils in another common plant, the pumpkin creeper.

**Study no. 1.** To observe the *general pattern of the tendrils* in the pumpkin creeper.

**Method.** 43 sets of tendrils in a single pumpkin creeper were observed with regard to the following points as shown in Figure 1.

- (a) the number of tendrils per tendril stalk.
- (b) the number of spirals in a tendril.
- (c) the number of turns in a spiral.

The tendrils springing from any given tendril stalk were numbered 1, 2, 3, ..... the number 1 being given to the stoutest tendril, no, 2 to the next stoutest tendril, and so on down to the thinnest tendril in the set. They usually formed a regular sequence, the fattest being at one end, the thinnest at the other end of the set of tendrils.

## Results and conclusions.

1. *Tendril stalk.* There was one tendril stalk in each leaf axil of the plant.
2. *Number of tendrils per tendril stalk* (Figure 1a). There were 4 or 5 tendrils per tendril stalk in nearly 90% of stalks. The range was 3-6.

---

\* Miss Rupani Weerasinghe, 424, Kurunegala Road, Uyanwatte, Nugawela.

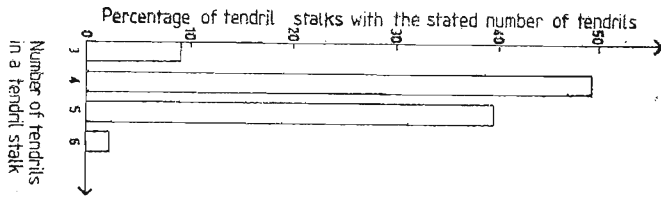

Figure 1A

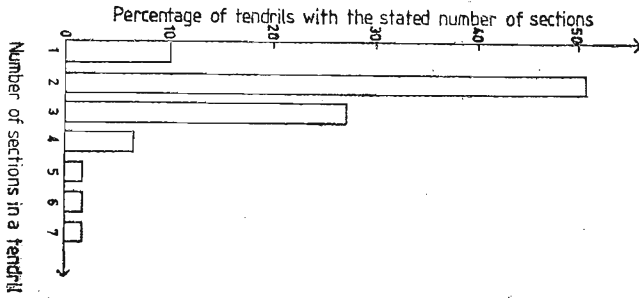

Figure 1B

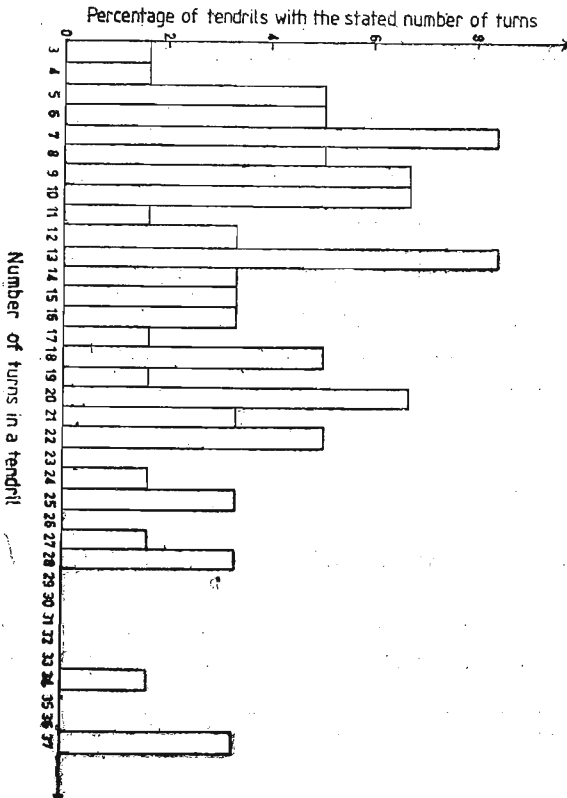
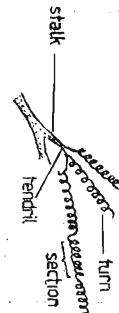

Figure 1C



3. *Number of spirals in a tendril* (Figure 1b). The modal value was two, the range was 1 - 7. About 27% of the tendrils had 3 spirals each.

4. *Total number of turns in a tendril* (Figure 1c). The range was large, 3 - 37. The commonest numbers seemed to be around 6, 12 and 20.

## Study No. 2. Growth of the tendril.

### Method

A tender tendril stalk was selected and the growth of its set of tendrils observed daily for 13 days. It was not possible to do this until the tendril stalk was sufficiently separate from the adjacent leaves. The tendrils at first were rolled up, and no measurements were made until they became unrolled and straight.

### Results and conclusions.

1. *Length of the tendril stalk* (Figure 2). Growth was slow at first, then rapid for a few days, and growth ceased after 6 days.

2. *Length of the tendril before it coils*. Figure 3 shows the data for two separate sets of tendrils (two tendril stalks).

The fattest tendril (tendril no. 1) grew fastest and most, the thinnest tendril (no. 5) grew slowest and least, and the others were intermediate.

3. *Total number of turns per tendril* (Figure 4).

The conclusions are the same as for the length of the tendril (section 2 above), i.e. the fattest tendril has the largest number of turns; the thinnest, least; others, intermediate.

4. *Lengthening of the stem of the creeper* (Figure 5).

The most distal part of the stem (distal to the last tendril stalk) grew fastest, about 20 cm/d. The next internode grew a little more slowly.

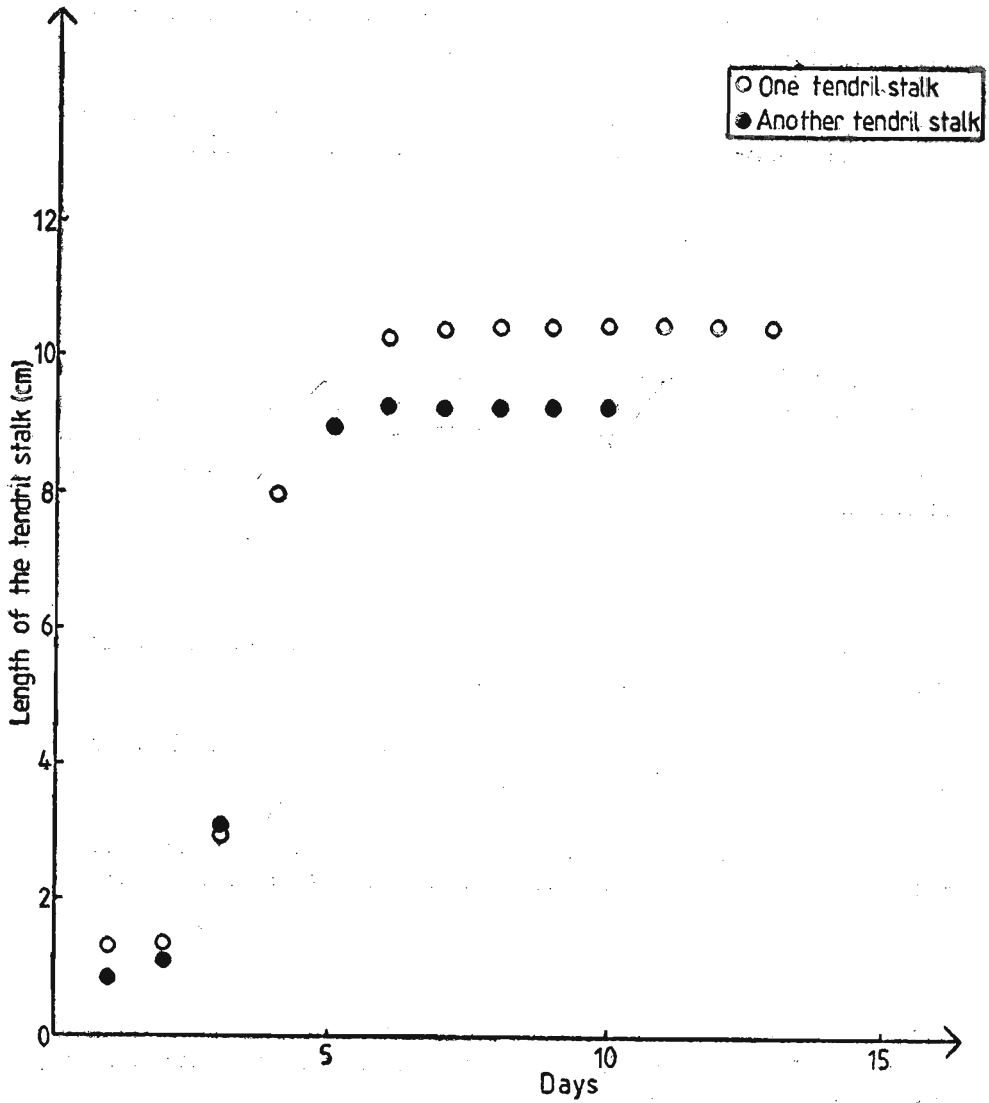

Figure 2. Growth of 2 selected tendrils of pumpkin

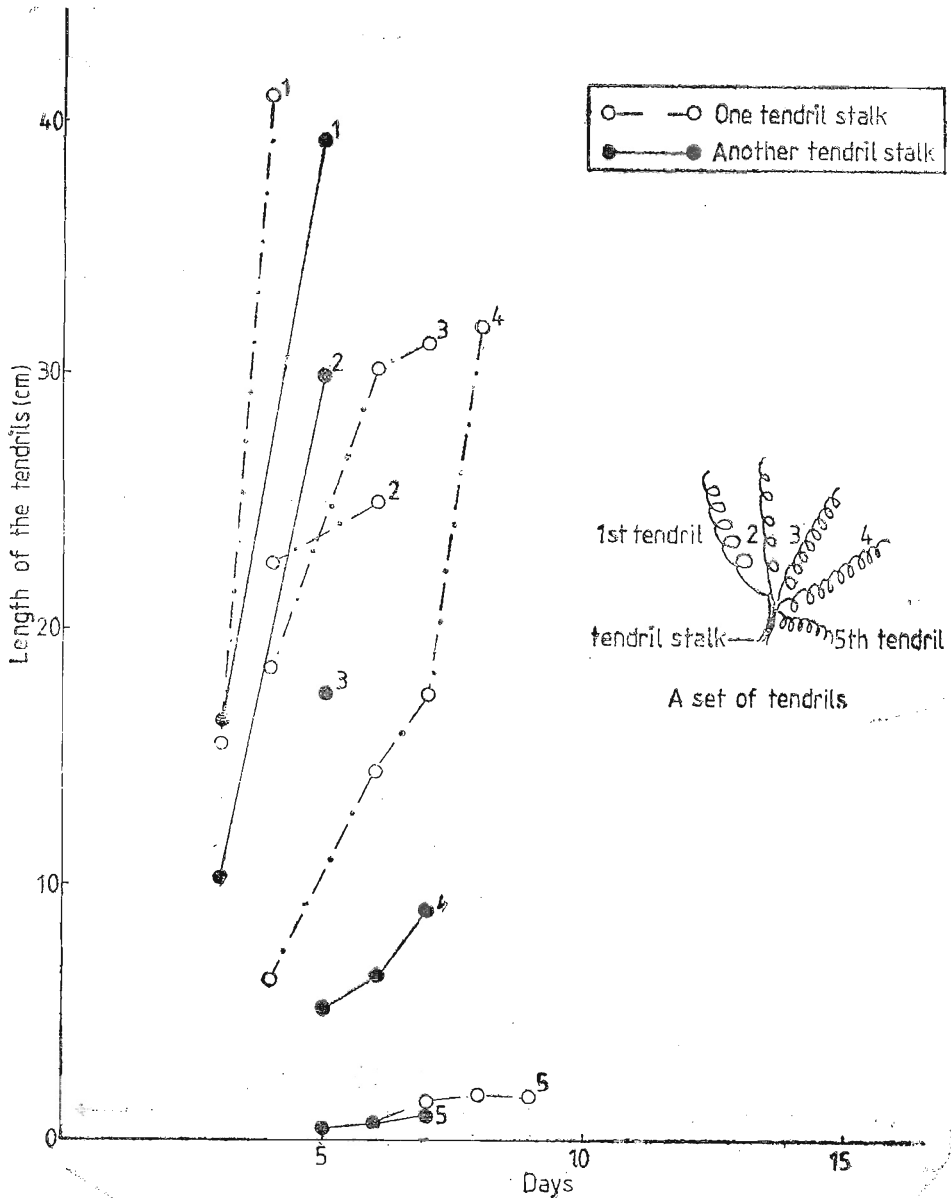

Figure 3. Growth in length of the pumpkin tendril before the tendril coils up. Data for selected sets of tendrils.

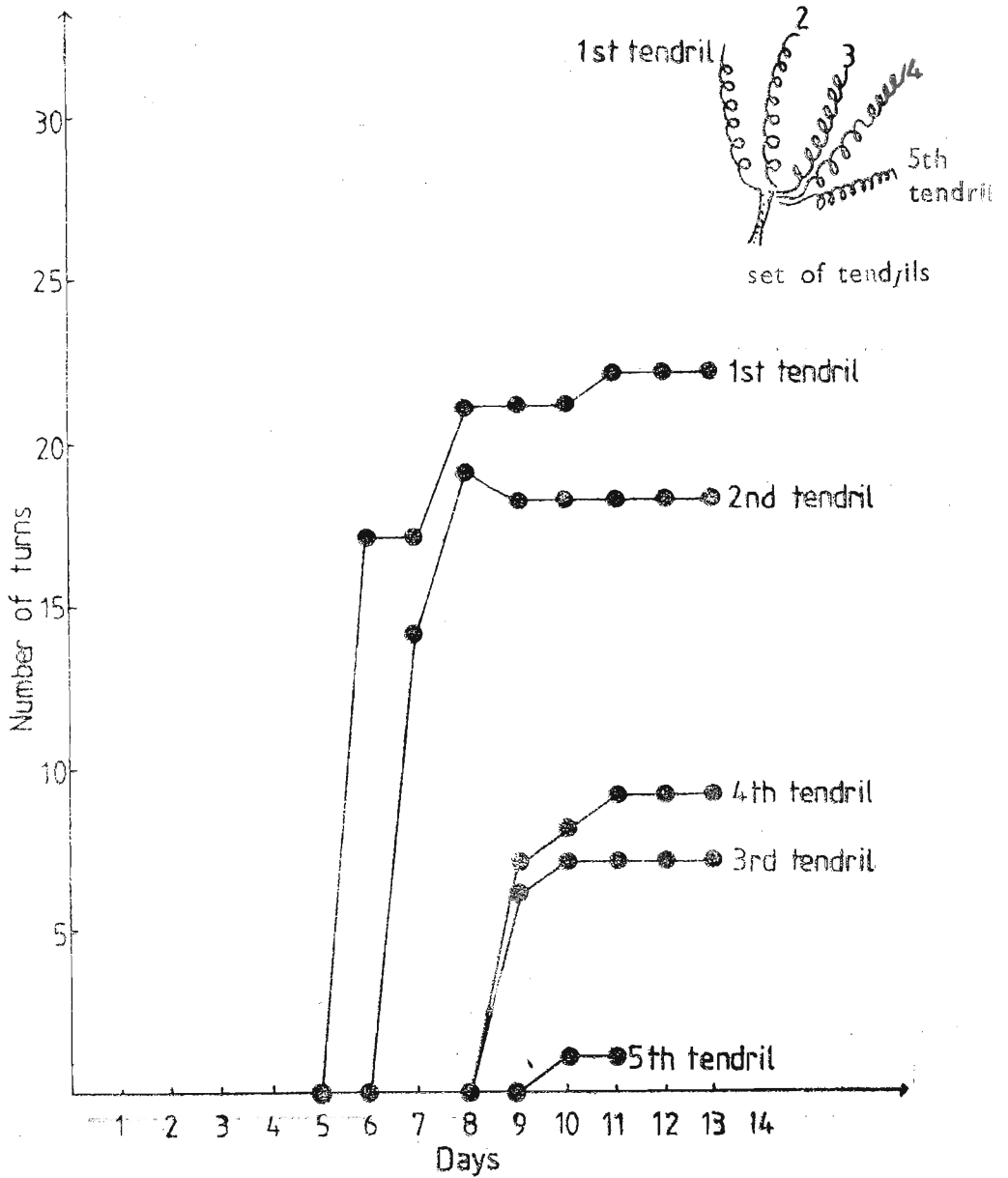

Figure 4. Total number of turns per tendril

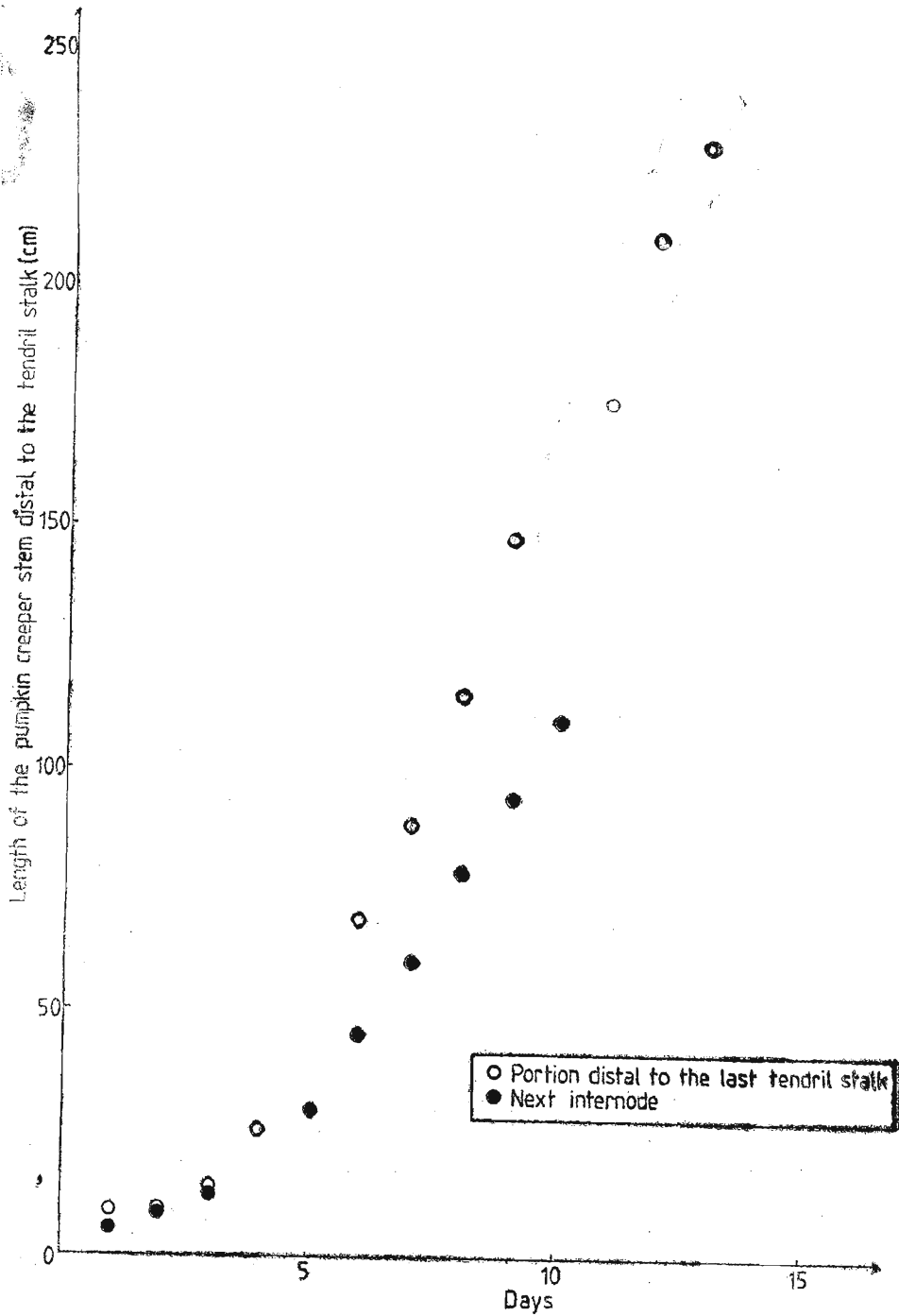

Figure 5 Growth of the tip of the pumpkin creeper

5. Number of sections and turns. Table 1

Table 1. Number of sections and turns in each of the tendrils of a single tendril stalk

Date	Tendril no. 1		2		3		4	
	No. of sections	No. of turns in the sections	No. of sections	No. of turns in the sections	No. of sections	No. of turns in the sections	No. of sections	No. of turns in the sections
July 1981								
23rd	3	8,5,4	—	—	—	—	—	—
24th	3	8,5,4	3	5,7,2	—	—	—	—
25th	3	10,6,5	3	7,9,3	—	—	—	—
26th	3	10,6,5	2	8,10	1	6	2	4,3
27th	3	10,6,5	2	8,10	1	7	2	4,4
28th	3	11,6,5	2	8,10	1	7	2	5,4
29th	3	11,6,5	2	8,10	1	7	2	5,4
30th	3	11,6,5	2	8,10	1	7	2	5,4

A spiral would appear overnight. Spirals were formed first in tendril no. 1 (fattest tendril) and last in the thinnest. The spirals were formed whether the tendril tip had become attached to an object or not. Once formed, the number of spirals per tendril could remain the same, or increase, or decrease, as the days passed. Thus in tendril no. 1, it stayed steady with 3 spirals, and nos. 3 and 4 with 1 – 2 spirals respectively, increased from 0 to 3 spirals and then settled with 2 spirals.

The number of turns per spiral was greatest in tendril nos. 1 and 2. The number of turns per spiral tended to increase with time. This was seen in all the spirals.

### Discussion

Many tendrils become so intertwined with one another as to make the type of observation reported above difficult or impossible. The present observations refer to tendrils which had escaped this complication.

The observations here show that there is much variability with regard to the number of parts (sections & turns) in tendrils, as noted by Dissanayake (1981) for two other species of plants.

## Summary

The tendrils in the pumpkin creeper sprang from a single stalk at each leaf axil. The stalk bore a number of tendrils, usually 4 or 5. Each tendril had sections, usually 2, and the total number of turns in a tendril was very variable but tended to be around 6, 12 or 20.

The growth of a tendril took place over a period of some 6 days. The stoutest tendril was also the fastest to grow. Spiral turns in the tendril appeared overnight. They appeared whether the tendril was attached or not. Once the spirals were formed, the number of spirals could increase, remain the same, or decrease.

## Reference

Dissanayake, A. Number of sections and turns in the tendrils of the bitter gourd and passion fruit creeper. *Science investigations* no. 1 (June 1981), pp 7 - 8.